

Vertical Machining Centers

MILLAC V II series

MILLAC 468V II / MILLAC 561V II

MILLAC 611V II / MILLAC 761V II

MILLAC 852V II / MILLAC 1052V II



MILLAC V II series

MILLAC 468V II / MILLAC 561V II / MILLAC 611V II
MILLAC 761V II / MILLAC 852V II / MILLAC 1052V II



MILLAC 611V II

Table size: 1,600 x 610 mm

OSP

FANUC

Integral motor/spindle Gear

No.50 20 to 4,000 min⁻¹

<Standard Specifications : Spindle speed>



MILLAC 761V II

Table size: 1,800 x 720 mm

OSP

FANUC

Integral motor/spindle Gear

No.50 20 to 4,000 min⁻¹

<Standard Specifications : Spindle speed>



MILLAC 852V II

Table size: 2,200 x 850 mm
3,200 x 850 mm

OSP

FANUC

Integral motor/spindle Gear

No.50 20 to 4,000 min⁻¹

<Standard Specifications : Spindle speed>



MILLAC 1052V II

Table size: 2,200 x 1,050 mm
3,200 x 1,050 mm

OSP

FANUC

Integral motor/spindle Gear

No.50 20 to 4,000 min⁻¹

<Standard Specifications : Spindle speed>



MILLAC 468V II

Table size: 1,050 x 460 mm

OSP

FANUC

Integral motor/spindle

No.40 50 to 15,000 min⁻¹

No.50 60 to 6,000 min⁻¹

<Standard Specifications : Spindle speed>



MILLAC 561V II

Table size: 1,350 x 560 mm

OSP

FANUC

Integral motor/spindle Gear

No.50 30 to 6,000 min⁻¹

<Standard Specifications : Spindle speed>



MILLAC V II Series for heavy-duty cutting of medium-sized and large parts

Highly rigid slide guideway structure for powerful cutting and reduced cycle time

Thermo-Friendly Concept enables improved productivity with high dimensional stability

Diverse lineup to meet all kinds of needs

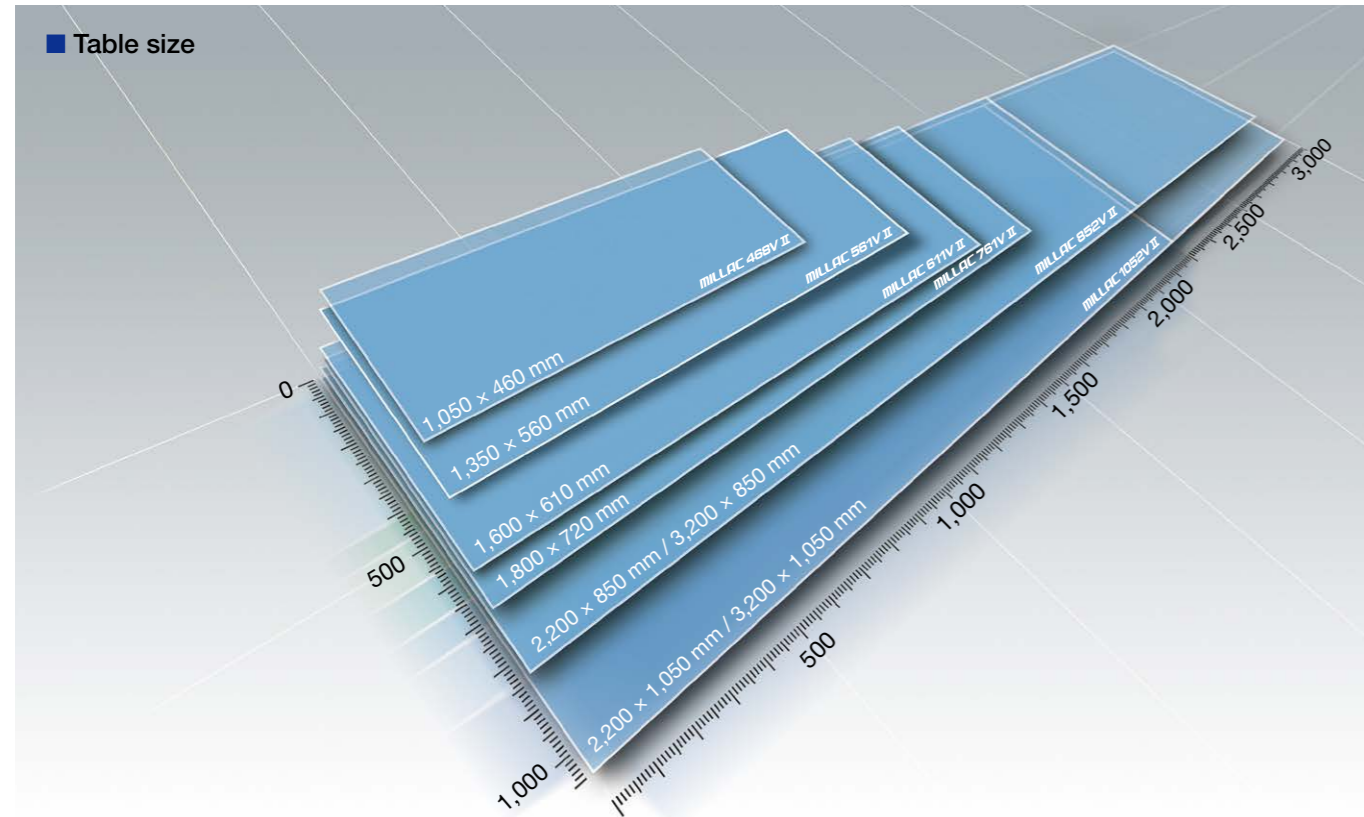

■ Spindle specifications

Standard Specifications

OSP Specifications			MILLAC 468V II	MILLAC 561V II	MILLAC 611V II	MILLAC 761V II	MILLAC 852V II	MILLAC 1052V II
No.40	Integral motor/spindle	Spindle speed [min ⁻¹]	50 to 15,000	80 to 12,000			50 to 15,000	
		Motor output	26/18.5 kW	22/18.5 kW			26/18.5 kW	
No.50	Integral motor/spindle	Spindle speed [min ⁻¹]	60 to 6,000	60 to 10,000			50 to 12,000	
		Motor output	18.5/11 kW	22/18.5 kW			26/18.5 kW	
	Gear	Spindle speed [min ⁻¹]			20 to 4,000	20 to 4,000		20 to 4,000
		Motor output			15/11 kW	18.5/15 kW		22/18.5 kW
No.50	Gear	Spindle speed [min ⁻¹]		30 to 6,000	30 to 6,000	30 to 6,000		30 to 6,000
		Motor output		15/11 kW	15/11 kW	18.5/15 kW		22/18.5 kW

FANUC Specifications			MILLAC 468V II	MILLAC 561V II	MILLAC 611V II	MILLAC 761V II	MILLAC 852V II	MILLAC 1052V II
No.40	Integral motor/spindle	Spindle speed [min ⁻¹]	50 to 15,000	80 to 12,000			50 to 15,000	
		Motor output	22/18.5 kW	22/18.5 kW			22/18.5 kW	
No.50	Integral motor/spindle	Spindle speed [min ⁻¹]	60 to 6,000	60 to 10,000			50 to 12,000	
		Motor output	18.5/11 kW	22/18.5 kW			22/18.5 kW	
	Gear	Spindle speed [min ⁻¹]			20 to 4,000	20 to 4,000		20 to 4,000
		Motor output			15/11 kW	18.5/15 kW		22/18.5 kW
No.50	Gear	Spindle speed [min ⁻¹]		30 to 6,000	30 to 6,000	30 to 6,000		30 to 6,000
		Motor output		15/11 kW	15/11 kW	18.5/15 kW		22/18.5 kW

Reliable, highly rigid construction allows for high-speed, heavy-duty cutting

Highly rigid construction

■ Bed column

Strong base column construction has optimally-placed ribs to counter chatter and twisting during heavy-duty cutting. Traditional box ways is used for all axes to give high accuracy and rigidity over the long term.

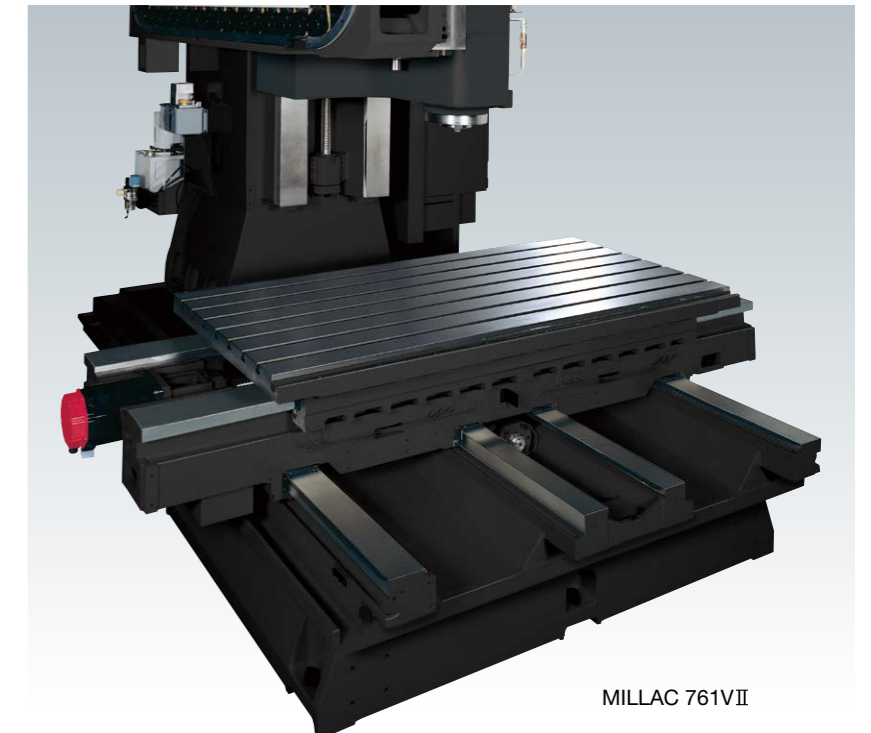

MILLAC 761V II

■ Machining Capacity

360 cm³/min

No.50 6,000 min⁻¹ 18.5 kW Integral motor/spindle
MILLAC 468V II

588 cm³/min

No.50 10,000 min⁻¹ 22 kW Integral motor/spindle
MILLAC 561V II

540 cm³/min

No.50 4,000 min⁻¹ 18.5 kW 2-speed gear head spindle
MILLAC 761V II, MILLAC 852V II

756 cm³/min

No.50 4,000 min⁻¹ 22 kW 2-speed gear head spindle
MILLAC 1052V II

Note: The "actual data" referred to above for this brochure represent examples, and may not be obtained due to differences in specifications, tooling, cutting, and other conditions.

Okuma Intelligent Technology for competitive machine shops

The innovation that accepts temperature changes
Thermo-Friendly Concept

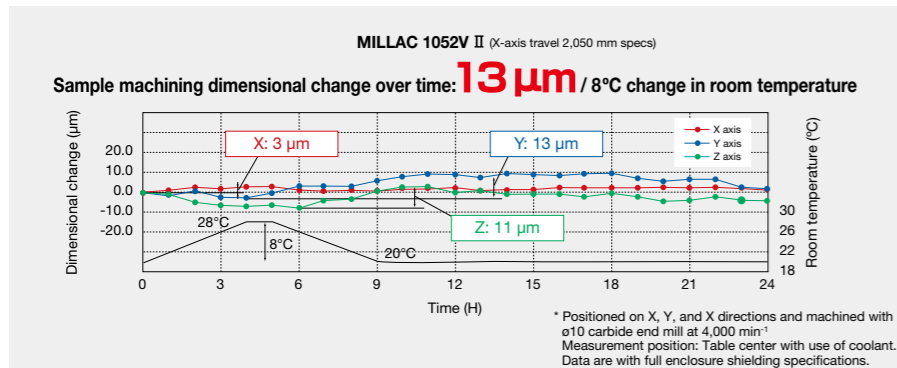
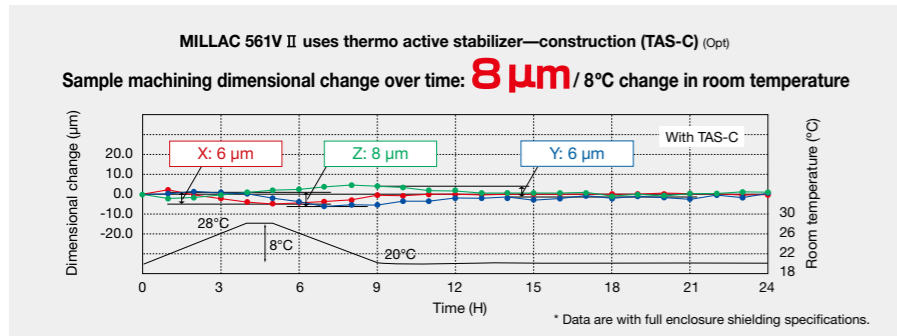

Eliminate waste with the Thermo-Friendly Concept

In addition to maintaining high dimensional accuracy when room temperature changes, Okuma's Thermo-Friendly Concept provides high dimensional accuracy during machine startup and machining restart. To stabilize thermal deformation, warming-up time is shortened and the burden of dimensional correction during machining restart is reduced.

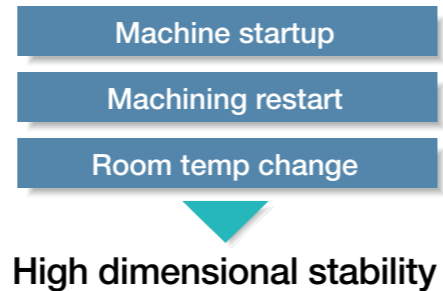

* The "actual data" referred to above for this brochure represent examples, and may not be obtained due to differences in specifications, tooling, cutting, and other conditions.

Thermo-Friendly structure gives outstanding thermal stability

TAS-C: Thermo Active Stabilizer—Construction
 "Proactively" keeps the machine [construction] in optimum, stable condition during shop environment temperature change—resulting in superb (stable) machining accuracies.

TAS-S: Thermo Active Stabilizer—Spindle
 Spindle deformation will be accurately controlled even during operations with frequent speed changes.

*Optional on MILLAC 468V II/561V II.
 Standard on MILLAC 611V II/761V II/852V II/1052V II

Machine tool idling stop

ECO Idling Stop

Only the necessary units run

Accuracy ensured, cooler off ECO Idling Stop

Intelligent energy-saving function with the Thermo-Friendly Concept. The machine itself determines whether or not cooling is needed and cooler idling is stopped with no loss to accuracy. (Standard application on machines with Thermo-Active Stabilizer—Spindle)

On-the-spot check of energy savings ECO Power Monitor

Power is shown individually for spindle, feed axes, and auxiliaries on the OSP operation screen. The energy-saving benefits from auxiliary equipment stopped with ECO Idling Stop can be confirmed on the spot.

ECO suite

(OSP-P300MA only)

ECO suite benefits

Electricity consumption during non-machining time greatly reduced with "ECO Idling Stop," which shuts down each piece of auxiliary equipment not in use.

ECO suite provides a suite of energy-saving functions that can be used on machines

- "ECO Idling Stop" for operation of necessary units only
- "ECO Power Monitor" for visual graphics of power
- Intermittent/continuous operation of chip conveyor and mist collector during operation—"ECO Operation" (Optional)

Cutting condition search for milling

Machining Navi M-i, M-gII+, M-gII* (Optional: OSP-P300MA only) * Harmonic Spindle Speed Control available only with M-i or M-gII+. (N/A with M-gII.)

Automatically changes to optimum spindle speed (M-i)

Built-in sensors measure chatter vibration and the machine automatically changes to the best spindle speed.

• Available only with Okuma integral motor/spindles. (N/A with gear spindles.)

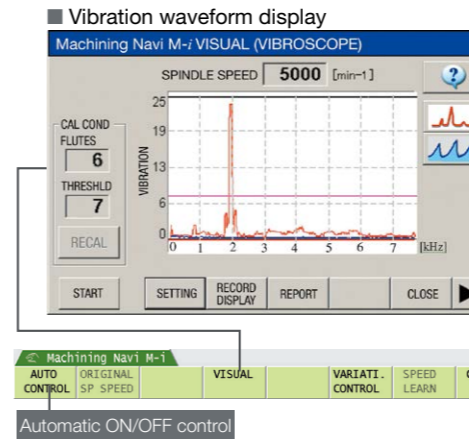

Adjust cutting conditions while monitoring the data (M-gII+, M-gII)

Navigates effective measures by detecting and analyzing machining chatter with a microphone attached to the machine.

- M-gII+ : compatible with integral spindles
- M-gII : compatible with gear spindles



This sign indicates a change to the optimum spindle speed.



This sign indicates that spindle speed is being changed.



This sign indicates that the cutting load needs to be reduced.

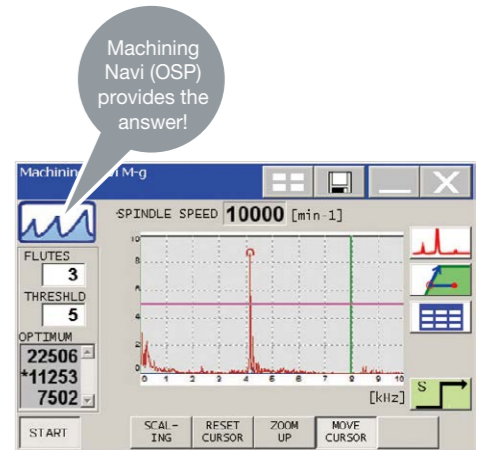

Optimized Servo Control

SERVONAVI (OSP-P300MA only)

Achieves long term accuracy and surface quality

SERVONAVI AI (Automatic Identification)

Cycle time shortened with faster acceleration Work Weight Auto Setting

On table travel type machining centers, the table feed acceleration with the previous system was the same regardless of weight, such as workpieces and fixtures loaded on the table.

Work Weight Auto Setting estimates the weight of the workpiece and fixture on the table and automatically sets servo parameters, including acceleration, to the optimum values. Cycle times are shortened with no changes to machining accuracy.

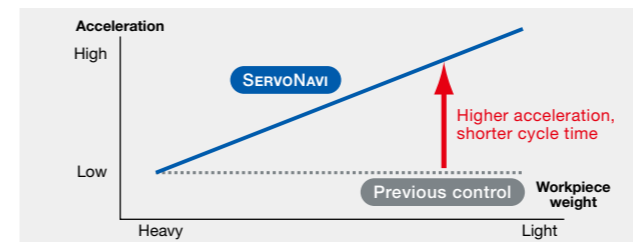

Collision prevention

Collision Avoidance System

(Optional: OSP-P300M only)

World's first "Collision-Free Machine"

CAS prevents collisions in automatic or manual mode, providing risk-free protection for the machine and great confidence for the operator.

SERVONAVI SF (Surface Fine-tuning)

Maintains machining accuracy and surface quality Reversal Spike Auto Adjustment

Slide resistance changes with length of time machine tools are utilized, and discrepancies occur with the servo parameters that were the best when the machine was first installed. This may produce crease marks at motion reversals and affect machining accuracy (part surface quality).

SERVONAVI's Reversal Spike Auto Adjustment maintains machining accuracy by switching servo parameters to the optimum values matched to changes in slide resistance.

Contributes to longer machine life Vibration Auto Adjustment

When aging changes machine performance, noise, vibration, crease marks, or fish scales may appear. Vibration Auto Adjustment can quickly eliminate noise and vibration even from machines with years of operation.

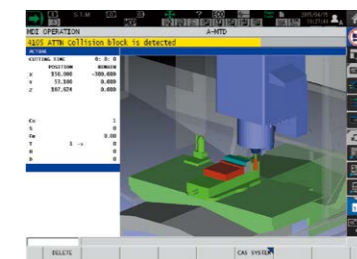

Vertical Machining Centers MILLAC 468V II

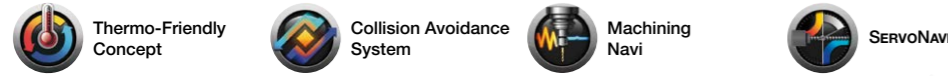

Machine Specifications

Photos shown in this brochure may also show optional equipment.

Item	Unit	MILLAC 468V II	
		No. 50 Specs	No. 40 Specs
Travels	X axis (table R/L)	mm (in.)	820 (32.28)
	Y axis (table F/B)	mm (in.)	460 (18.11)
	Z axis (spindle U/D)	mm (in.)	450 (17.72)
	Table top to spindle nose	mm (in.)	150 to 600 (5.91 to 23.62)
	Column to spindle center	mm (in.)	510 (20.08)
Table	Work surface	mm (in.)	1,050 × 460 (41.34 × 18.11)
	Floor to table top	mm (in.)	930 (36.61)
	Max load capacity	kg (lb)	500 (1,100)
Spindle	Spindle speed	min ⁻¹	60 to 6,000
	Speed ranges		Stepless (integral motor/spindle)
	Tapered bore		7/24 taper No. 50
	Bearing dia	mm (in.)	ø90 (3.54)
			ø70 (2.76)
Feedrate	Rapid traverse	m/min (fpm)	X-Y: 32, Z: 24 (X-Y: 105, Z: 79)
	Cutting feedrate	mm/min (ipm)	X-Y-Z: 15,000 (591)
Motors	Spindle	kW (hp)	OSP 18.5/11 (25/15) (15%ED/cont) FANUC 18.5/11 (25/15) (40%ED/cont)
ATC	Tool storage	tool	20 [30]
	Max tool dia (w, w/o adj tool)	mm (in.)	ø120/ø150 (ø4.72/ø5.91)
	Max tool length	mm (in.)	350 (13.78)
	Max tool weight	kg (lb)	20 (44)
Machine size	Height	mm (in.)	2,790 (109.84)
	Floor space	mm (in.)	OSP: 2,265 × 2,805 (89.17 × 110.43), FANUC: 2,200 × 2,780 (86.61 × 109.45)
	Weight	kg (lb)	6,700 (14,740)
Control			OSP-P300MA, FANUC 31i-B

[]: Optional

Spindle torque/output graphs

No. 50 6,000 min⁻¹ spindle (OSP)
Maximum output: 18.5/11 kW (15%ED/cont)
Maximum torque: 326/175 N-m (15%ED/cont)

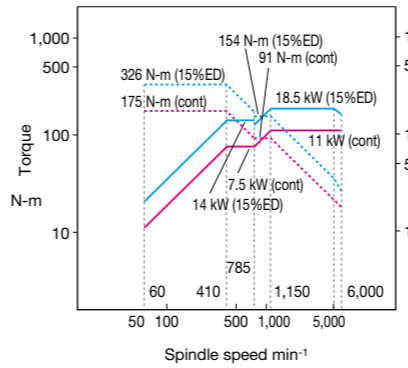

No. 50 6,000 min⁻¹ spindle (FANUC)
Maximum output: 18.5/11 kW (40%ED/cont)
Maximum torque: 326/175 N-m (15%ED/cont)

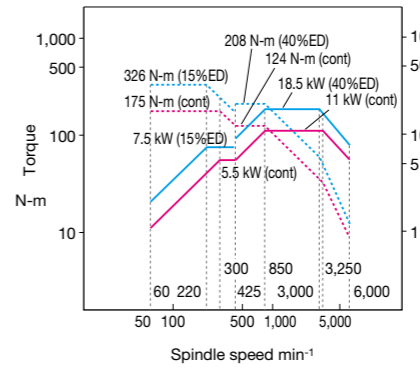

No. 40 15,000 min⁻¹ spindle (OSP)
Maximum output: 26/18.5 kW (10 min/cont)
Maximum torque: 199/146 N-m (5 min/cont)

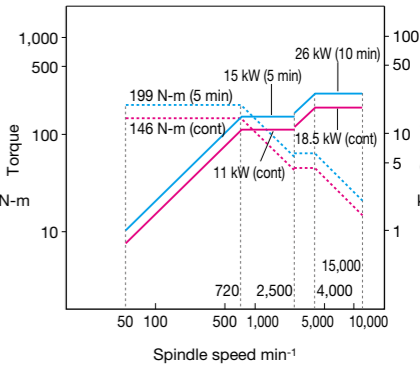

Dimensional drawing/Installation drawing

Unit: mm (in.)

No. 50 6,000 min⁻¹,
OSP-P300MA specs
[]: FANUC specs

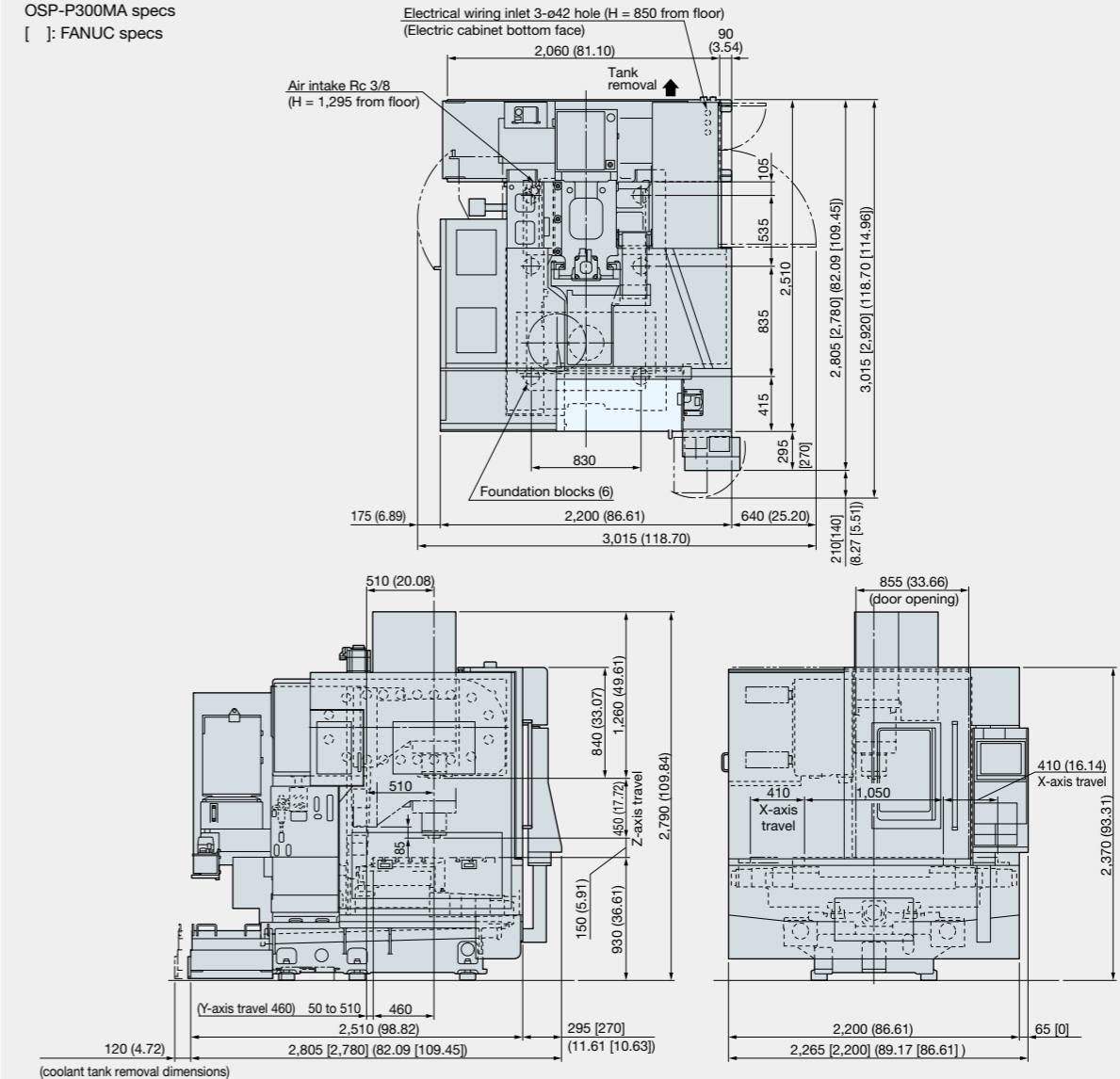

Machining Capacity (Material: S45C)

	Tool	Cutting Capacity (cm ³ /min) (in ³ /min)	Cutting Speed (m/min) (fpm)	Cutting Depth (mm) (in.)	Cutting Width (mm) (in.)	Feedrate (mm/min) (ipm)
No.50 Spindle 6,000 min ⁻¹ integral motor	ø125 face mill 8 blades	360 (21.98)	148 (485.59)	5 (0.20)	90 (3.54)	800 (31.50)

Note: The "actual data" referred to above for this brochure represent examples, and may not be obtained due to differences in specifications, tooling, cutting, and other conditions.

Standard Specifications · Accessories

Specifications	Remarks	Specifications	Remarks
CNC	OSP-P300MA	In-machine conveyor	Gutter: Coil type (1 each left and right)
	FANUC 31i-B	Chip pan	
Spindle speed	60 to 6,000 min ⁻¹ No. 50 Integral motor	Coolant supply system	Tank: 200 L, Pump motor: 180 W
	Spindle motor 18.5/11 kW	Coolant nozzle	3 flexible nozzles
	50 to 15,000 min ⁻¹ No. 40 Integral motor	Work lamp	LED
	Spindle motor 26/18.5 kW (OSP) 22/18.5 kW (FANUC)	Spindle air curtain	
Spindle nose constraint	BIG-PLUS® (No. 50)	Air cleaner (filter)	Including regulator
Spindle cooling system	Oil controller	Door interlock	
ATC magazine	20 tools	Pulse handle	Single axis, switchable
ATC air blower		Electronic buzzer	At operation end and alarm times
Full-enclosure	With ceiling	Foundation blocks / Jack bolts	
Slideway lubricating equipemnt		Tool / Tool box	Hand tools
		Tool release lever	

Optional Specifications · Options

Specifications	Remarks	Specifications	Remarks
ATC magazine	30 tools (both No. 40, No. 50)	Reference tool	
Chip air blower	Nozzle type	Ring gauge	
Coolant pump	Pump motor 370 W	High column	+ 200 mm, including full enclosure shielding for high columns
Coolant nozzle	Ring type	Auto gauging, auto zero offset	Infrared communication type
Semi-dry unit	Nozzle type, Thru-spindle type	Auto tool length compensation/auto tool breakage detection function	Touch type
Coolant level sensor		Pulse handle	3-axis round handle, 3-axis round handle + 1-axis mobile type switch
Coolant temperature regulator		TAS-S: Thermo Active dimension Stabilizer – Spindle (OSP)	
Oil hole device	0.5 MPa, 1.5 MPa	TAS-C: Thermo Active dimension Stabilizer – Construction (OSP)	
Thru-spindle coolant	Okuma pull stud for 1.5 MPa, 1.5 MPa large capacity, and 7 MPa required.	Spindle thermal deformation compensation (FANUC)	
Spindle nose constraint	BIG-PLUS® (No. 40)	Ambient thermal deformation compensation (FANUC)	
In-machine chip discharge	Oil pan: chip flusher type	AbsoScale detection (OSP)	X-Y-Z axis
Off-machine chip discharge	Hinge conveyor, scraper conveyor See recommended chip conveyor specifications, P31.	Scale feedback (FANUC)	X-Y-Z axis
Chip bucket	Tilt with/without	Status indicator	
Raised machine	20 mm	Foundation bolt	
Workpiece washing gun		Rotary 2-pallet APC	Forms set together with below options. High column 200 mm Pallet size 820 × 460 mm Tap pallet, T-slot pallet Full enclosure shielding for 2-pallet rotary-shuttle APC
Air gun mount			
Angle head preps			
Manual clamp fixture			
Hydraulic and pneumatic fixtures			
Oil skimmer	Belt type		
Mist collector			
Auto open/close front cover			
Rotary table	NC, tilt, indexing		
Sub table	1,050 × 460 × 70 mm		

Maximum tool dimensions

Unit: mm (in.)

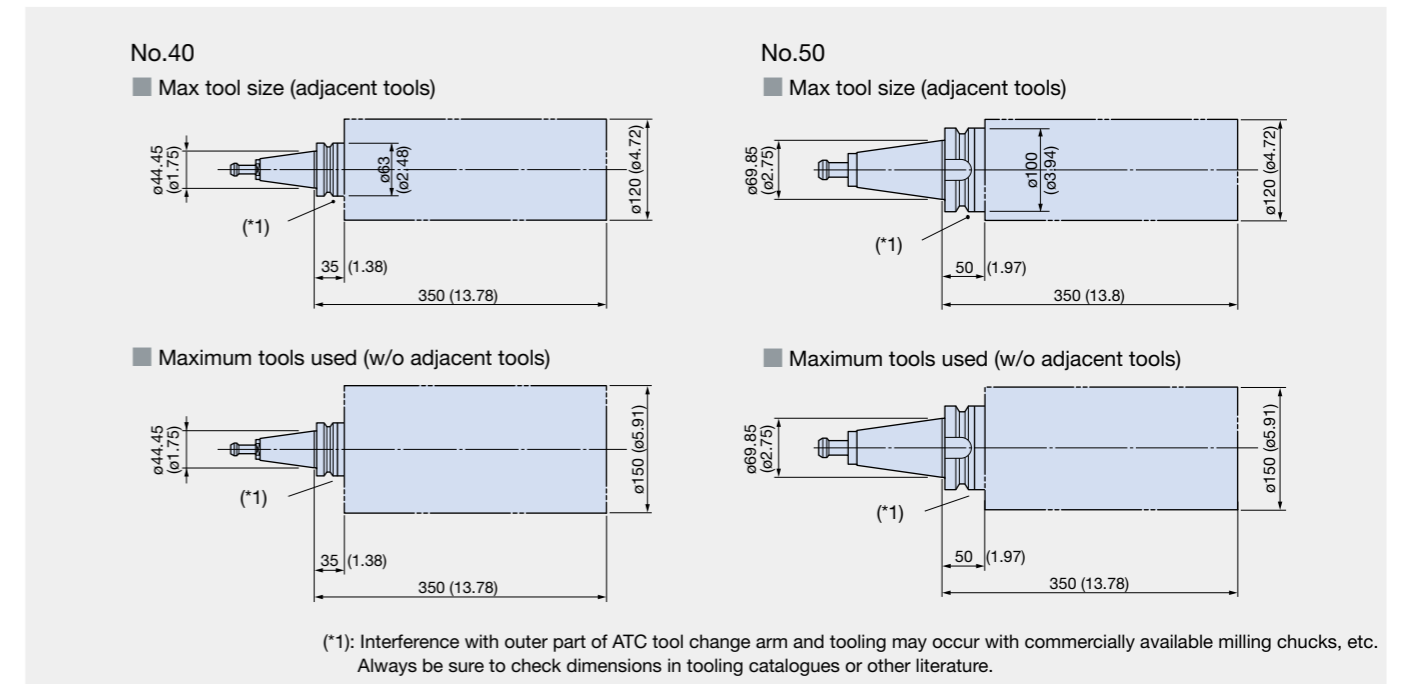
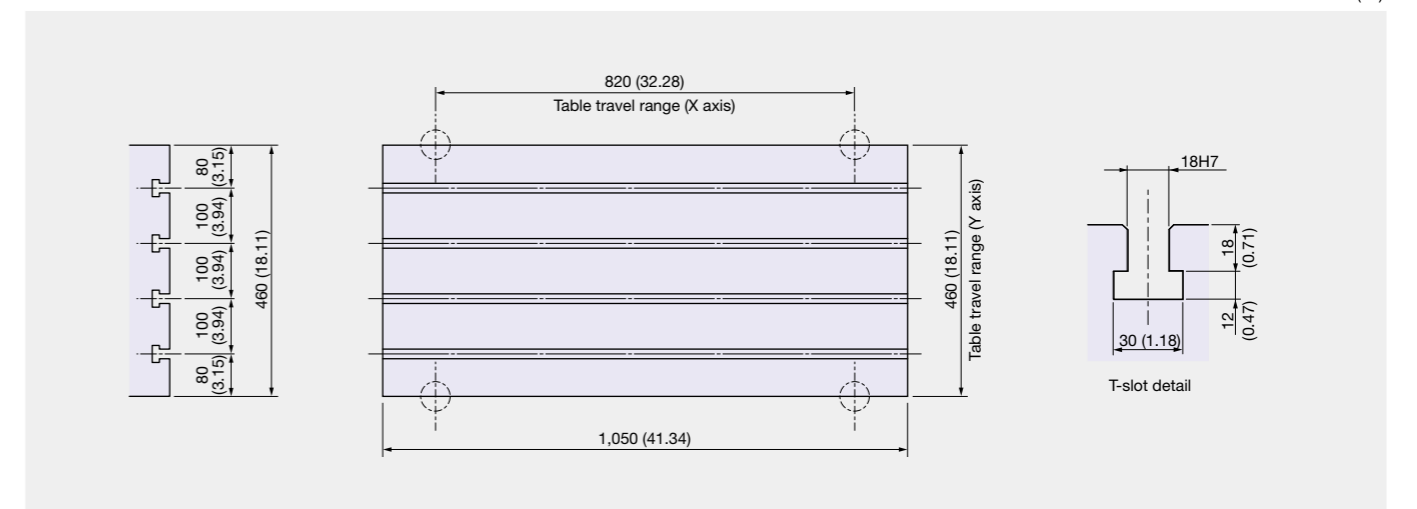

Table size

Unit: mm (in.)



Working range

Unit: mm (in.)

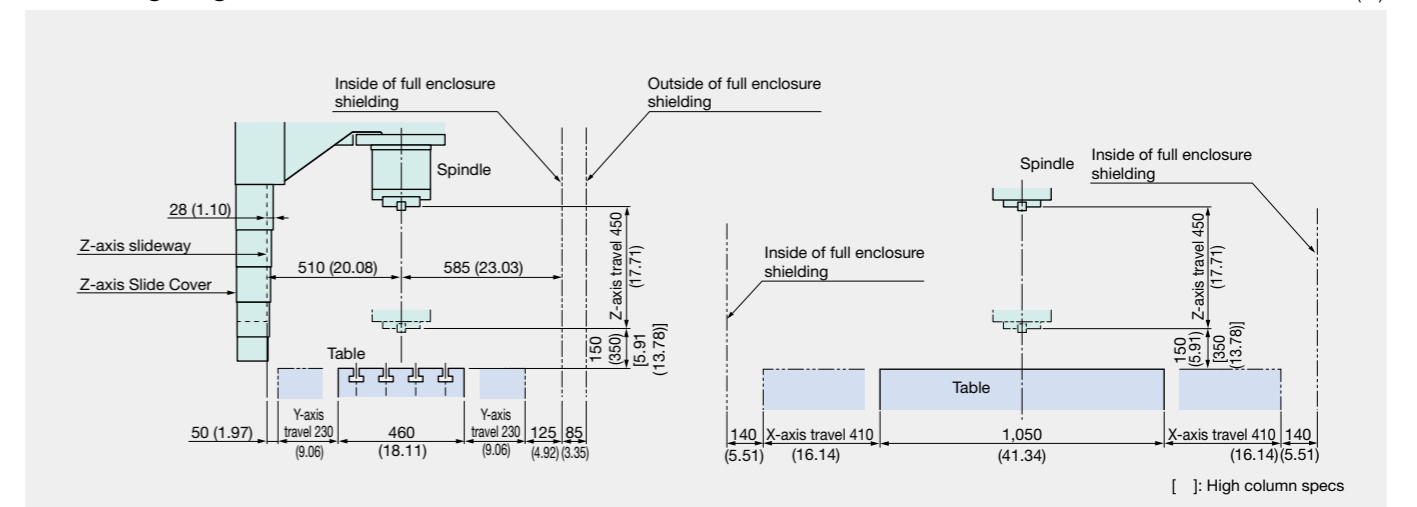

Vertical Machining Centers MILLAC 561V II



Machine Specifications

Photos shown in this brochure may also show optional equipment.

Item	Unit	MILLAC 561V II			
		No. 50 6,000 min ⁻¹	No. 50 10,000 min ⁻¹	No. 40 12,000 min ⁻¹	
Travels	X axis (table R/L)	mm (in.)	1,050 (41.34)		
	Y axis (table F/B)	mm (in.)	560 (22.05)		
	Z axis (spindle U/D)	mm (in.)	520 (20.47)		
	Table top to spindle nose	mm (in.)	170 to 690 (6.69 to 27.17)		
	Column to spindle center	mm (in.)	590 (23.23)		
Table	Work surface	mm (in.)	1,350 × 560 (53.15 × 22.05)		
	Floor to table top	mm (in.)	950 (37.40)		
	Max load capacity	kg (lb)	1,000 (2,200)		
Spindle	Spindle speed	min ⁻¹	30 to 6,000	60 to 10,000	80 to 12,000
	Speed ranges		2-speed		Stepless (integral motor/spindle)
	Tapered bore		7/24 taper No. 50		7/24 taper No. 40
	Bearing dia	mm (in.)	ø100 (3.94)		ø70 (2.76)
	Feedrate		X-Y: 32, Z: 24 (X-Y: 105, Z: 79)		
Motors	Spindle	kW (hp)	15/11 (20/15) (30 min/cont)		22/18.5 (30/25) (15 min/cont)
	ATC	Tool storage	tool	20 [30, 40]	
Machine size	Max tool dia (w, w/o adj tool)	mm (in.)	ø120/ø150 (ø4.72/ø5.91)		ø90/ø115 (ø3.54/ø4.53)
	Max tool length	mm (in.)	350 (13.78)		300 (13.78)
	Max tool weight	kg (lb)	20 (44)		8 (11)
Machine size	Height	mm (in.)	2,755 (108.46)	2,930 (115.35)	2,825 (111.22)
	Floor space	mm (in.)	2,650 × 3,285 (104.33 × 129.33)		
	Weight	kg (lb)	9,100 (20,020)		
Control			OSP-P300MA, FANUC 31i-B		

[]: Optional

Spindle torque/output graphs

No. 50 6,000 min⁻¹ spindle (OSP, FANUC)
Maximum output: 15/11 kW (30 min/cont)
Maximum torque: 376/276 N-m (30 min/cont)

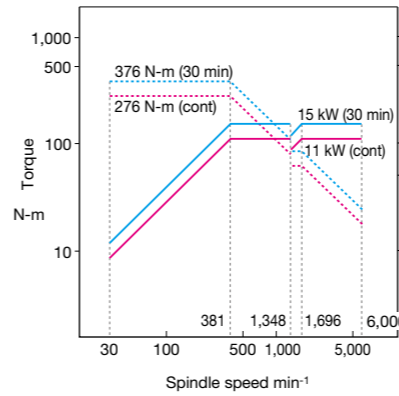

No. 50 10,000 min⁻¹ spindle (OSP)
Maximum output: 23.7/18.5 kW (3 min/cont)
Maximum torque: 205/125 N-m (3 min/cont)

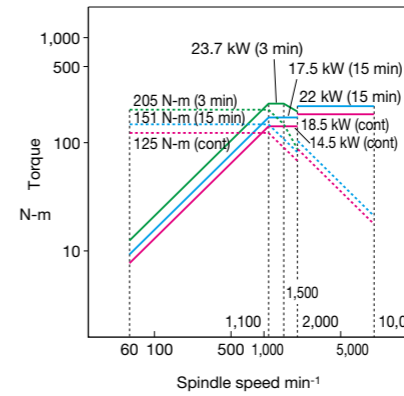

No. 50 10,000 min⁻¹ spindle (FANUC)
Maximum output: 22/18.5 kW (15 min/cont)
Maximum torque: 204/119 N-m (25%ED/cont)

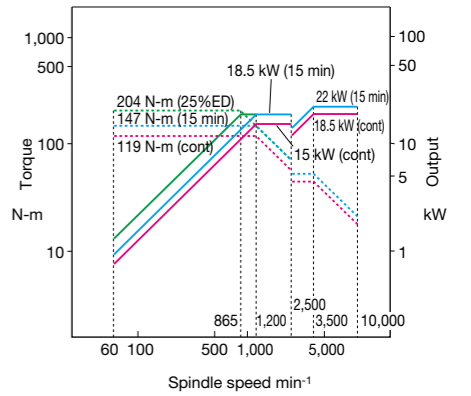

Dimensional drawing/Installation drawing

Unit: mm (in.)

No. 50 6,000 min⁻¹ specs

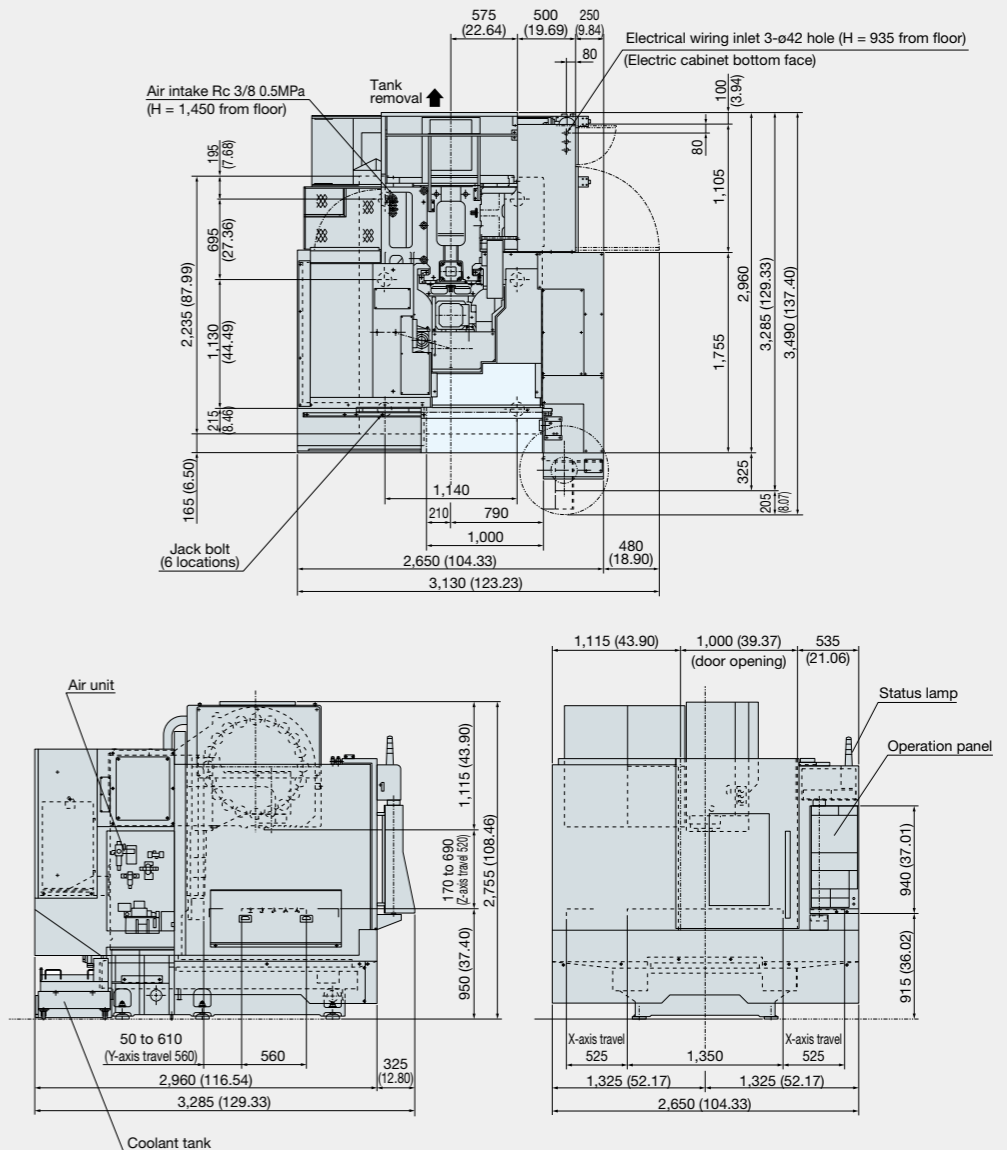

Machining Capacity (Material: S45C)

	Tool	Cutting Capacity (cm ³ /min) (in ³ /min)	Cutting Speed (m/min) (fpm)	Cutting Depth (mm) (in.)	Cutting Width (mm) (in.)	Feedrate (mm/min) (ipm)
No. 50 spindle 6,000 min ⁻¹ 2-speed gear head	ø125 face mill, 6 blades	252 (15.38)	120 (393.72)	7 (0.28)	90 (3.54)	400 (15.75)
No.50 Spindle 10,000 min ⁻¹ integral motor (optional)	ø80 face mill, 6 blades	588 (35.90)	250 (820.25)	5 (0.20)	56 (2.20)	2,100 (82.68)
No.40 Spindle 12,000 min ⁻¹ integral motor (optional)	ø100 face mill, 5 blades	350 (21.37)	170 (557.77)	5 (0.20)	70 (2.76)	1,000 (39.37)

Note: The "actual data" referred to above for this brochure represent examples, and may not be obtained due to differences in specifications, tooling, cutting, and other conditions.

Standard Specifications · Accessories

Specifications	Remarks	Specifications	Remarks
CNC	OSP-P300MA	Chip pan	
	FANUC 31i-B	Coolant supply system	Tank: 200 L, Pump motor: 180 W
Spindle speed	6,000 min ⁻¹ No. 50 2-speed gear head spindle Spindle motor 15/11 kW	Coolant nozzle	3 flexible nozzles
		Work lamp	LED
		Spindle air curtain	
Spindle nose constraint	BIG-PLUS®	Air cleaner (filter)	Including regulator
Spindle cooling system	Oil controller	Door interlock	
ATC magazine	20 tools	Pulse handle	Single axis, switchable
ATC air blower		Electronic buzzer	At operation end and alarm times
Full-enclosure	With ceiling	Foundation blocks / Jack bolts	
Slideway lubricating equipemnt		Tool / Tool box	Hand tools
In-machine conveyor	Gutter: chip flusher type	Tool release lever	

Optional Specifications · Options

Specifications	Remarks	Specifications	Remarks
Spindle speed 10,000 min ⁻¹	No. 50 integral motor/spindle 22/18.5 kW	Auto open/close front cover	
Spindle speed 12,000 min ⁻¹	No. 40 integral motor/spindle 22/18.5 kW	Rotary table	NC, tilt, indexing
ATC magazine	40 tools; 30 tools possible with No. 50 spindle only	Sub table	1,350 × 560 × 90 mm
Chip air blower	Nozzle type	Reference tool	
Coolant pump	Pump motor 370 W	Ring gauge	
Coolant nozzle	Ring type	High column	+200 mm
Semi-dry unit	Nozzle type, Thru-spindle type	Auto gauging, auto zero offset	Infrared communication type
Coolant level sensor		Auto tool length compensation/auto tool breakage detection function	Touch type
Coolant temperature regulator		TAS-S: Thermo Active dimension Stabilizer - Spindle (OSP)	
Oil hole device	0.5 MPa, 1.5 MPa	TAS-C: Thermo Active dimension Stabilizer - Construction (OSP)	
Thru-spindle coolant	Okuma pull stud for 1.5 MPa, 1.5 MPa large capacity, and 7 MPa required.	Spindle thermal deformation compensation (FANUC)	
In-machine chip discharge	Oil pan: Chip flush Gutter: Coil type, 1 each left and right	Ambient thermal deformation compensation (FANUC)	
Off-machine chip discharge	Hinge conveyor, scraper conveyor See recommended chip conveyor specifications, P31.	AbsoScale detection (OSP)	X-Y-Z axis
Chip bucket	Tilt with/without	Scale feedback (FANUC)	X-Y-Z axis
Raised machine	50 mm	Status lamp	
Workpiece washing gun		Foundation bolt	
Air gun mount		Parallel 2-pallet APC Forms set together with below options. High column 200 mm Pallet size 1,150 × 520 mm Tap pallet, T-slot pallet Hydraulic unit (APC drive)	
Angle head preps			
Manual clamp fixture			
Hydraulic and pneumatic fixtures			
Oil skimmer	Belt type		
Mist collector			

Maximum tool dimensions

Unit: mm (in.)

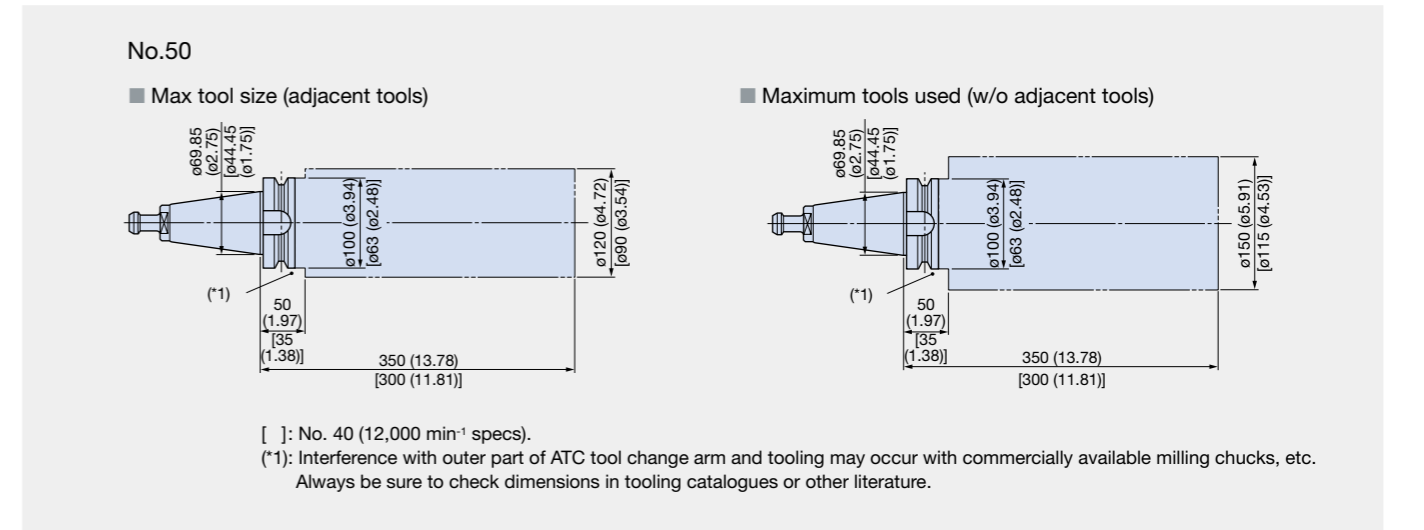
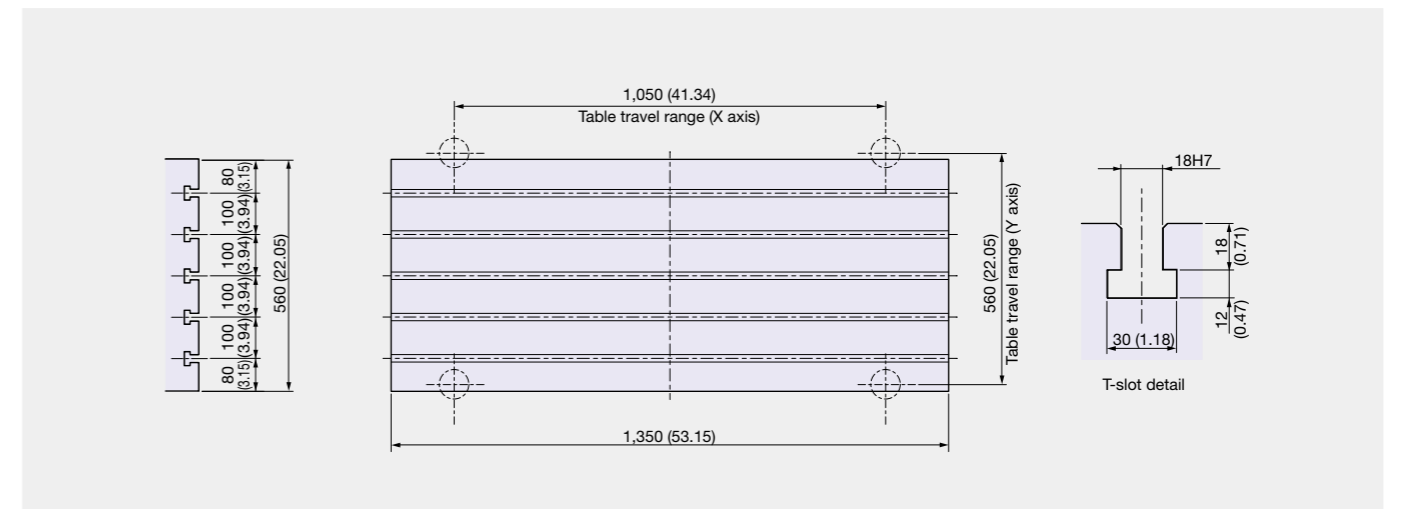

Table size

Unit: mm (in.)



Working range

Unit: mm (in.)

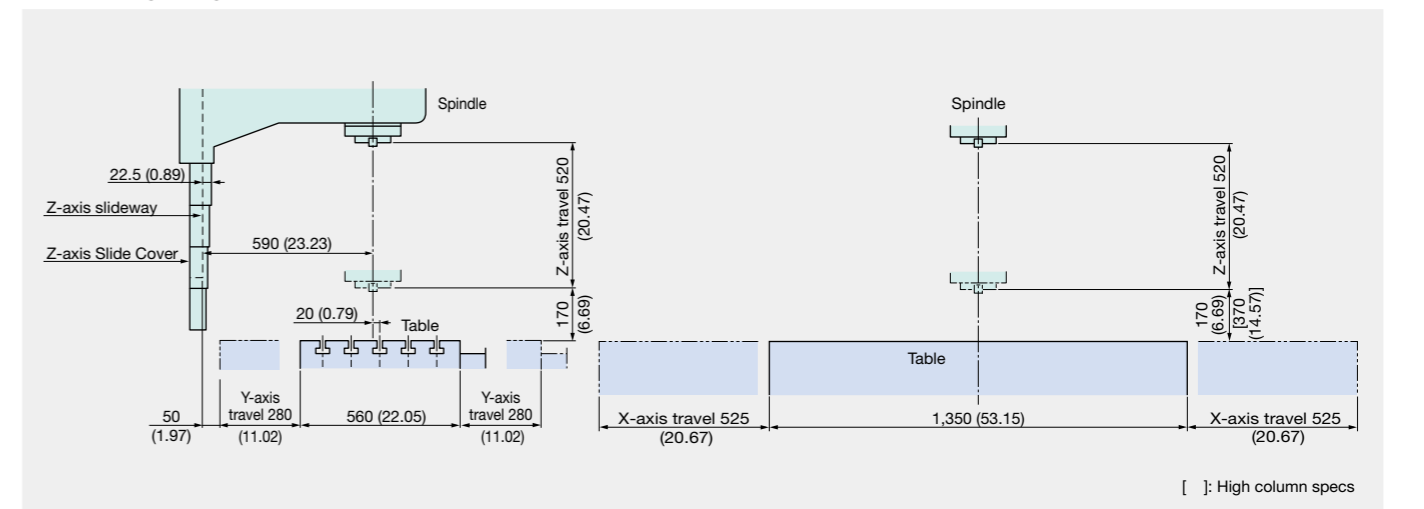

Vertical Machining Centers MILLAC 611V II

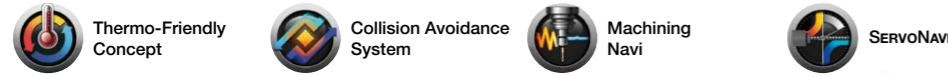

Machine Specifications

This operation panel is standard.
Photos shown in this brochure may also show optional equipment.

Item	Unit	MILLAC 611V II			
		No. 50 4,000 min ⁻¹	No. 50 6,000 min ⁻¹	No. 50 12,000 min ⁻¹	No. 40 15,000 min ⁻¹
Travels	X axis (table R/L)	1,300 (51.18)			
	Y axis (table F/B)	610 (24.02)			
	Z axis (spindle U/D)	560 (22.05)			
	Table top to spindle nose	200 to 760 (7.87 to 29.92)			
	Column to spindle center	650 (25.59)			
Table	Work surface	1,600 × 610 (62.99 × 24.02)			
	Floor to table top	900 (35.43)			
	Max load capacity	1,500 (3,300)			
	Spindle				
Spindle	Spindle speed	20 to 4,000	30 to 6,000	50 to 12,000	50 to 15,000
	Speed ranges	2-speed		Stepless (integral motor/spindle)	
	Tapered bore	7/24 taper No. 50			7/24 taper No. 40
	Bearing dia	ø100 (3.94)		ø90 (3.54)	ø70 (2.76)
Feedrate	Rapid traverse	X-Y: 20, Z: 16 (X-Y: 66, Z: 52)			
	Cutting feedrate	X-Y-Z: 10,000 (394)			
Motors	Spindle	15/11 (20/15) (30 min/cont)		OSP:26/18.5 (35/25) (10 min/cont) FANUC:22/18.5 (30/25) (15 min/cont)	
ATC	Tool storage	20 [30, 42]			
	Max tool dia (w, w/o adj tool)	ø120/ø150 (ø4.72/ø5.91)			ø115/ø115 (ø4.53/ø4.53)
	Max tool length	400 (15.75)			300 (11.81)
	Max tool weight	20 (44)			8 (11)
Machine size	Height	2,910 (114.57)			
	Floor space	3,410 × 3,695 (134.25 × 145.47)		3,410 × 3,525 (134.25 × 138.78)	
	Weight	11,000 (24,200)			
Control		OSP-P300MA, FANUC 311-B			

[]: Optional

Spindle torque/output graphs

No. 50 4,000 min⁻¹ spindle (OSP, FANUC)
Maximum output: 15/11 kW (30 min/cont)
Maximum torque: 512/376 N-m (30 min/cont)

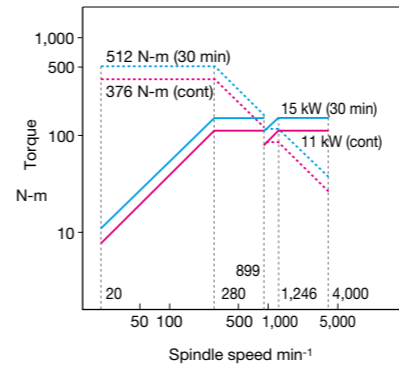

No. 50 6,000 min⁻¹ spindle (OSP, FANUC)
Maximum output: 15/11 kW (30 min/cont)
Maximum torque: 376/276 N-m (30 min/cont)

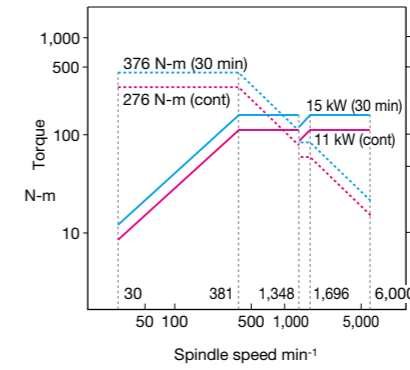

No. 50 12,000 min⁻¹ spindle (OSP)
Maximum output: 26/18.5 kW (10 min/cont)
Maximum torque: 199/146 N-m (5 min/cont)

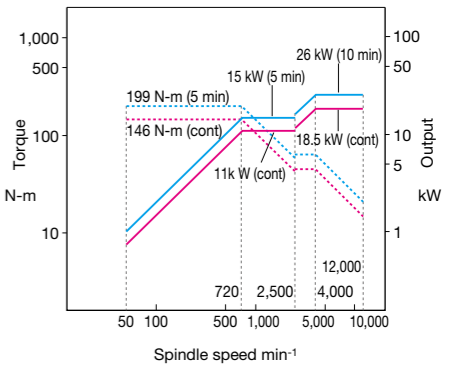

Dimensional drawing/Installation drawing

Unit: mm (in.)

No. 50 4,000/6,000 min⁻¹ specs

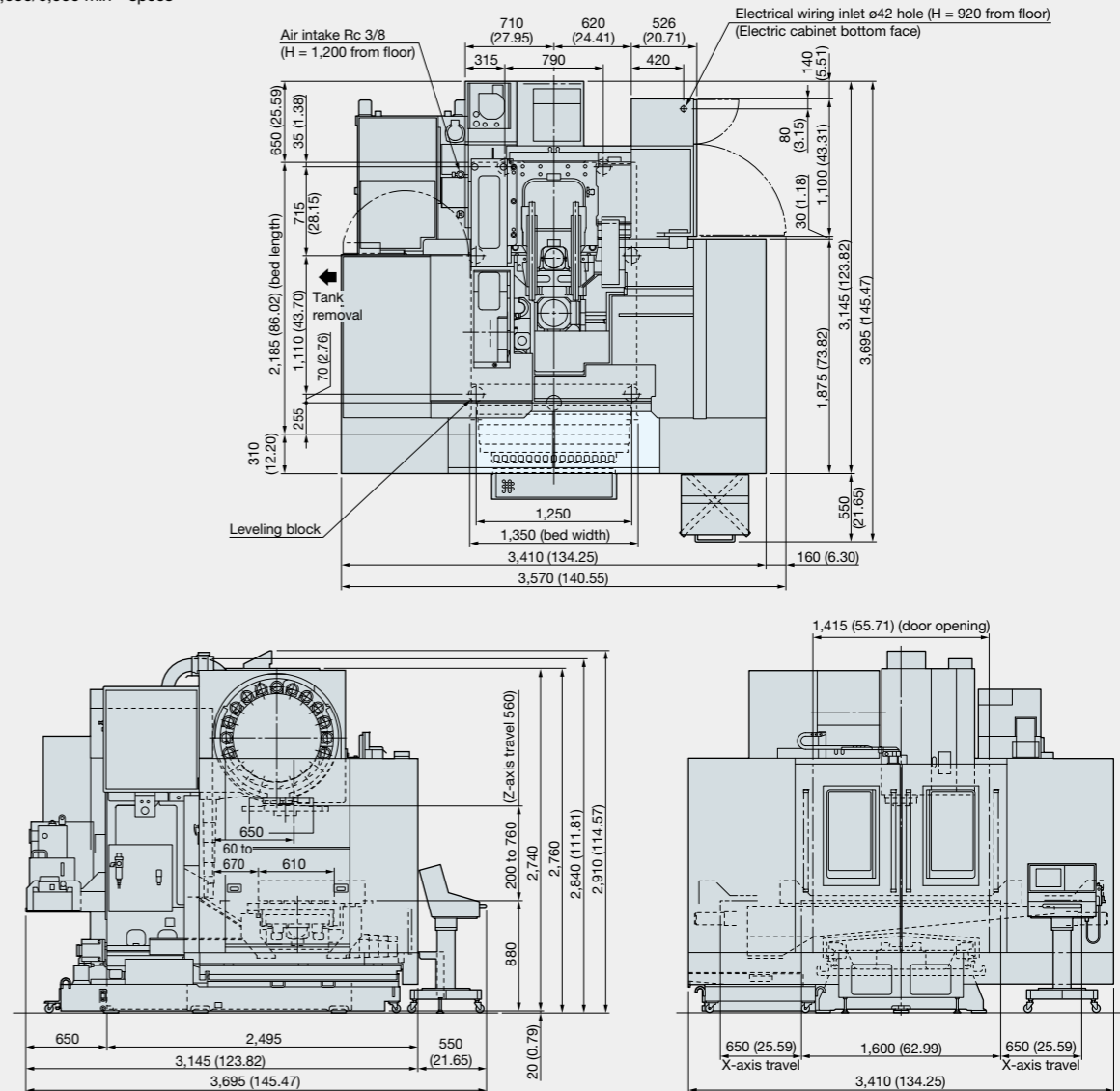

Machining Capacity (Material: S45C)

	Tool	Cutting Capacity (cm ³ /min) (in ³ /min)	Cutting Speed (m/min) (fpm)	Cutting Depth (mm) (in.)	Cutting Width (mm) (in.)	Feedrate (mm/min) (ipm)
No. 50 spindle 4,000 min ⁻¹ 2-speed gear head	ø125 face mill, 6 blades	304 (18.56)	120 (393.72)	5 (0.20)	90 (3.54)	675 (26.57)

Note: The "actual data" referred to above for this brochure represent examples, and may not be obtained due to differences in specifications, tooling, cutting, and other conditions.

Standard Specifications · Accessories

Specifications	Remarks	Specifications	Remarks
CNC	OSP-P300MA FANUC 31i-B	Spindle air curtain Air cleaner (filter)	
Spindle speed	4,000 min ⁻¹ No. 50 2-speed gear head spindle Spindle motor 15/11 kW	Door interlock Pulse handle Electronic buzzer	Including regulator Single axis, switchable At operation end and alarm times
Spindle nose constraint	BIG-PLUS® (No.50 4,000, 6,000 min ⁻¹ specs)	Foundation blocks / Jack bolts Tool / Tool box	
Spindle cooling system	Oil controller	Tool release lever	
ATC magazine	20 tools	Bed-mounted operation panel	
ATC air blower		TAS-S: Thermo Active dimension	
Full-enclosure	With ceiling	Stabilizer - Spindle (OSP)	
Slideway lubricating equipemnt		TAS-C: Thermo Active dimension	
In-machine chip discharge	Table rear: Coil	Stabilizer - Construction (OSP)	
Chip pan		Spindle thermal deformation compensation (FANUC)	
Coolant supply system	Tank: 350 L, Pump motor: 180 W	Ambient thermal deformation compensation (FANUC)	
Coolant nozzle	3 flexible nozzles		
Work lamp	LED		

Optional Specifications · Options

Specifications	Remarks	Specifications	Remarks
Spindle speed 6,000 min ⁻¹	No. 50 2-speed gear head spindle 15/11 kW	Raised machine Workpiece washing gun	100 mm
Spindle speed 12,000 min ⁻¹	No. 50 integral motor/spindle 26/18.5 kW (OSP) 22/18.5 kW (FANUC)	Air gun mount Angle head preps Manual clamp fixture	
Spindle speed 15,000 min ⁻¹	No. 40 integral motor/spindle 26/18.5 kW (OSP) 22/18.5 kW (FANUC)	Hydraulic and pneumatic fixtures Oil skimmer Mist collector	Belt type
ATC magazine	30 tools, 42 tools	Rotary table	NC, tilt, indexing
Chip air blower	Nozzle type	Sub table	1,600 × 610 × 90 mm
Coolant pump	Pump motor 370 W	Reference tool	
Coolant nozzle	Ring type	Ring gauge	
Semi-dry unit	Nozzle type, Thru-spindle type	High column	+200 mm
Coolant level sensor		Auto gauging, auto zero offset	Infrared communication type
Coolant temperature regulator		Auto tool length compensation/auto tool breakage detection function	Touch type
Oil hole device	0.5 MPa, 1.5 MPa	Main operating panel pendant type	
Thru-spindle coolant	Okuma pull stud for 1.5 MPa, 1.5 MPa large capacity, and 7 MPa required.	AbsoScale detection (OSP) Scale feedback (FANUC) Status lamp	X-Y-Z axis X-Y-Z axis
Spindle nose constraint	BIG-PLUS® No. 50 12,000 min ⁻¹ No. 40 15,000 min ⁻¹	Foundation bolt	
In-machine chip discharge	Table rear: Coil chip conveyor Oil pan: Chip flush	Parallel 2-pallet APC	Forms set together with below options. High column 200 mm Pallet size 1,400 × 580 mm Tap pallet, T-slot pallet
Off-machine chip discharge	Hinge conveyor, scraper conveyor See recommended chip conveyor specifications, P31.		
Chip bucket	Tilt with/without		

Maximum tool dimensions

Unit: mm (in.)

No.50

■ Max tool size (adjacent tools)

■ Maximum tools used (w/o adjacent tools)

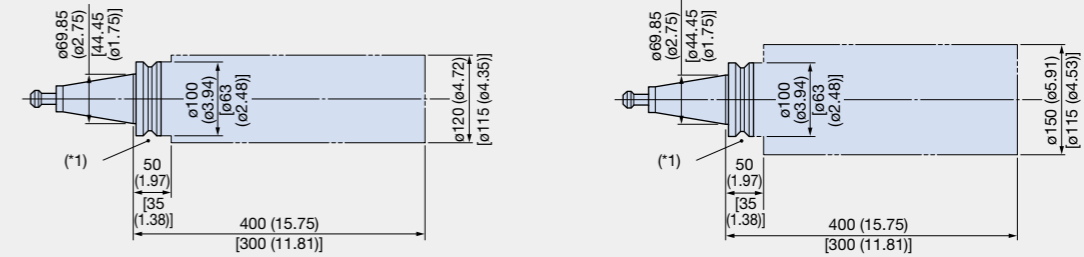

[] : No. 40 (15,000 min⁻¹ specs).

(*1): Interference with outer part of ATC tool change arm and tooling may occur with commercially available milling chucks, etc. Always be sure to check dimensions in tooling catalogues or other literature.

Table size

Unit: mm (in.)

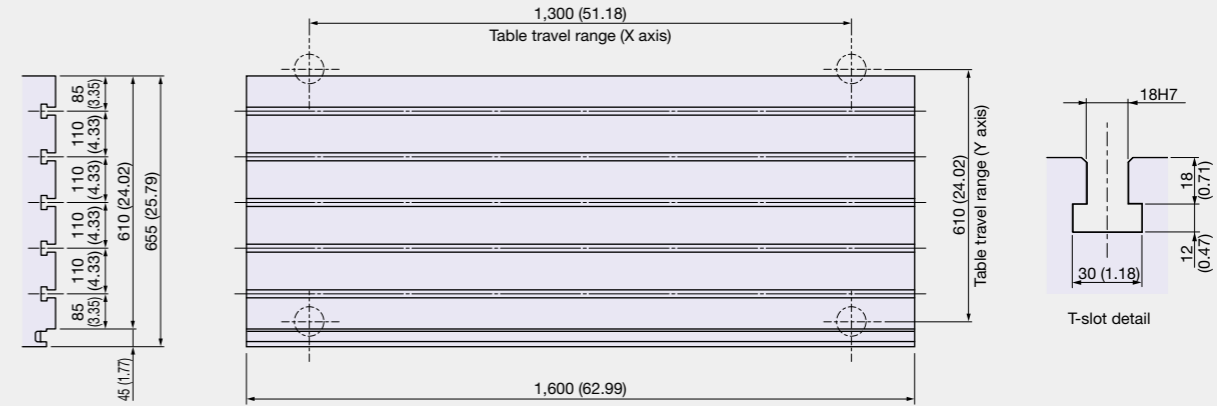

Working range

Unit: mm (in.)

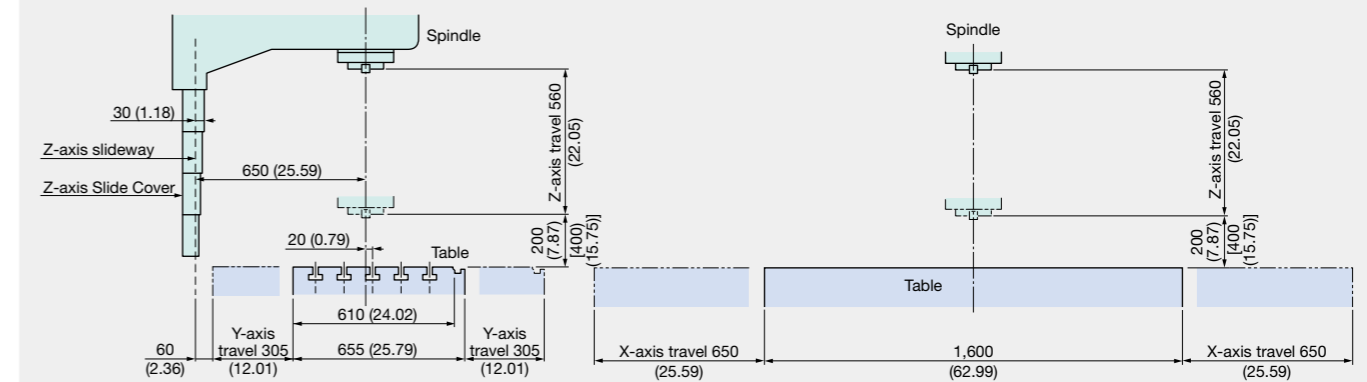

[] : High column specs

Vertical Machining Centers

MILLAC 761V II



Machine Specifications

Photos shown in this brochure may also show optional equipment.

Item	Unit	MILLAC 761V II			
		No. 50 4,000 min ⁻¹	No. 50 6,000 min ⁻¹	No. 50 12,000 min ⁻¹	No. 40 15,000 min ⁻¹
Travels	X axis (table R/L)	1,540 (60.63)			
	Y axis (table F/B)	760 (29.92)			
	Z axis (spindle U/D)	660 (25.98)			
	Table top to spindle nose	200 to 860 (7.87 to 33.86)			
	Column to spindle center	800 (31.50)			
Table	Work surface	1,800 × 720 (70.87 × 28.35)			
	Floor to table top	1,030 (40.55)			
	Max load capacity	2,000 (4,400)			
Spindle	Spindle speed	20 to 4,000	30 to 6,000	50 to 12,000	50 to 15,000
	Speed ranges	2-speed		Stepless (integral motor/spindle)	
	Tapered bore	7/24 taper No. 50			7/24 taper No. 40
	Bearing dia	ø100 (3.94)	ø90 (3.54)		ø70 (2.76)
	Feedrate	Rapid traverse	X-Y-Z: 16 (52)		
Motors	Cutting feedrate	X-Y-Z: 10,000 (394)			
	Spindle	18.5/15 (25/20) (30 min/cont)		OSP:26/18.5 (35/25) (10 min/cont) FANUC:22/18.5 (30/25) (15 min/cont)	
ATC	Tool storage	36 [54]			
	Max tool dia (w, w/o adj tool)	ø120/ø200 (ø4.72/ø5.91)			ø115/ø115 (ø4.53/ø4.53)
	Max tool length	400 (15.75)			300 (11.81)
	Max tool weight	20 (44)			8 (11)
Machine size	Height	3,230 (127.17)			
	Floor space	4,300 × 4,060 (169.29 × 159.84)			
	Weight	14,300 (31,460)			
Control		OSP-P300MA, FANUC 31i-B			

[]: Optional

Spindle torque/output graphs

No. 50 4,000 min⁻¹ spindle (OSP, FANUC)
Maximum output: 18.5/15 kW (30 min/cont)
Maximum torque: 587/476 N-m (30 min/cont)

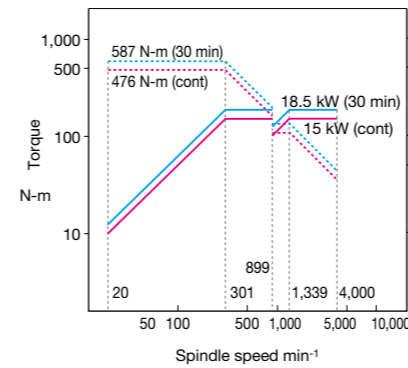

No. 50 6,000 min⁻¹ spindle (OSP, FANUC)
Maximum output: 18.5/15 kW (30 min/cont)
Maximum torque: 481/390 N-m (30 min/cont)

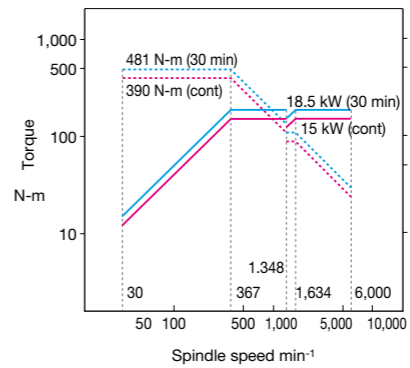

No. 50 12,000 min⁻¹ spindle (OSP)
Maximum output: 26/18.5 kW (10 min/cont)
Maximum torque: 199/146 N-m (5 min/cont)

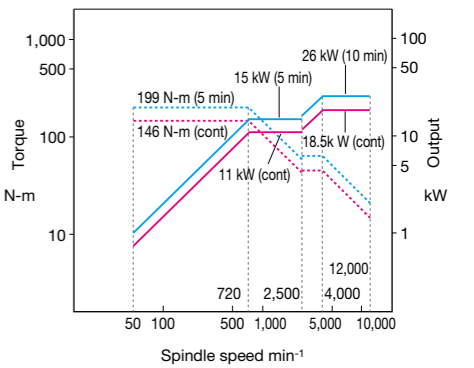

Dimensional drawing/Installation drawing

Unit: mm (in.)

No. 50 4,000/6,000 min⁻¹ specs

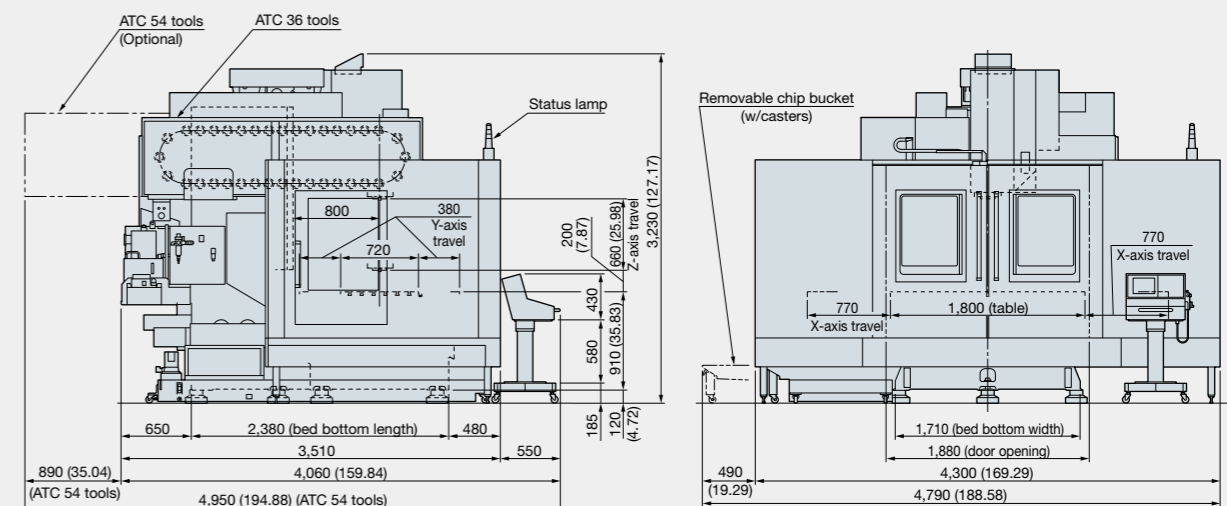
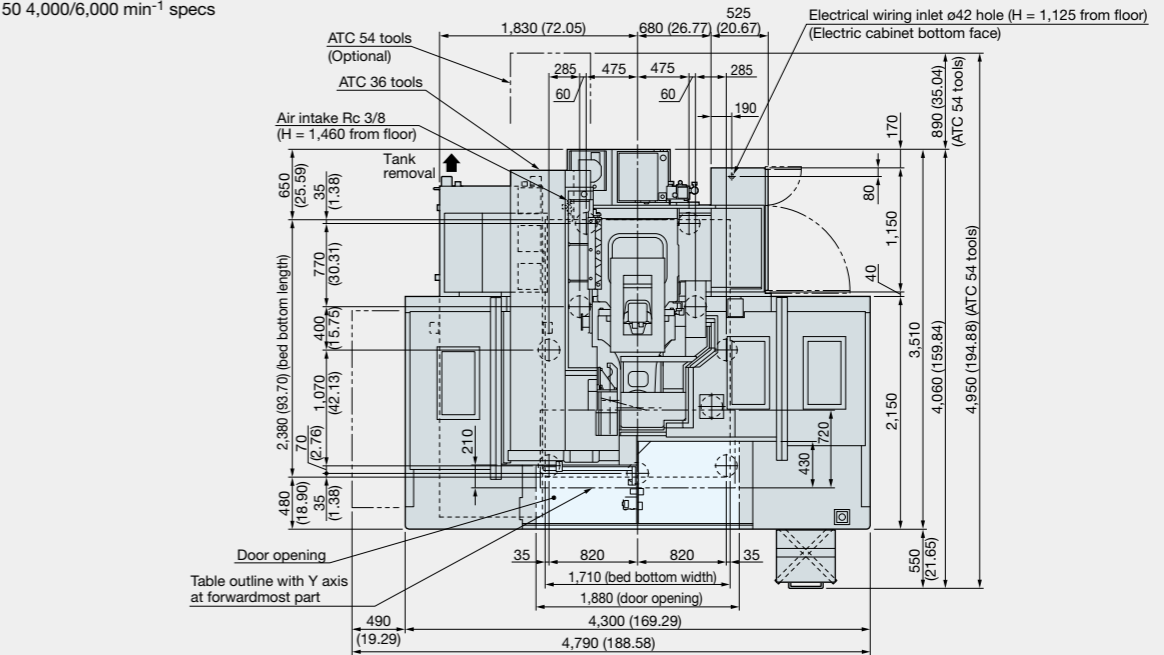

Machining Capacity (Material: S45C)

	Tool	Cutting Capacity (cm ³ /min) (in ³ /min)	Cutting Speed (m/min) (fpm)	Cutting Depth (mm) (in.)	Cutting Width (mm) (in.)	Feedrate (mm/min) (ipm)
No. 50 spindle 4,000 min ⁻¹ 2-speed gear head	ø150 face mill 8 blades	540 (32.96)	165 (541.37)	5 (0.20)	90 (3.54)	1,200 (47.24)
		485 (29.61)	165 (541.37)	7 (0.28)	90 (3.54)	770 (30.31)
	ø40 roughing end mill	252 (15.38)	25 (82.03)	40 (1.57)	30 (1.18)	210 (8.27)
		252 (15.38)	25 (82.03)	30 (1.18)	40 (1.57)	210 (8.27)

Note: The "actual data" referred to above for this brochure represent examples, and may not be obtained due to differences in specifications, tooling, cutting, and other conditions.

Standard Specifications · Accessories

Specifications	Remarks	Specifications	Remarks
CNC	OSP-P300MA FANUC 31i-B	Spindle air curtain Air cleaner (filter)	
Spindle speed	4,000 min ⁻¹ No. 50 2-speed gear head spindle Spindle motor 18.5/15 kW	Door interlock Pulse handle Electronic buzzer	Including regulator Single axis, switchable At operation end and alarm times
Spindle nose constraint	BIG-PLUS® (No. 50 4,000, 6,000 min ⁻¹ specs)	Foundation blocks / Jack bolts Tool / Tool box	Hand tools
Spindle cooling system	Oil controller	Tool release lever	
ATC magazine	36 tools	Bed-mounted operation panel	
ATC air blower		TAS-S: Thermo Active dimension	
Full-enclosure	With ceiling	Stabilizer - Spindle (OSP)	
Slideway lubricating equipemnt		TAS-C: Thermo Active dimension	
In-machine conveyor	Table rear: Coil	Stabilizer - Construction (OSP)	
Chip pan		Spindle thermal deformation	
Coolant supply system	Tank: 400 L, Pump motor: 250 W	compensation (FANUC)	
Coolant nozzle	3 flexible nozzles	Ambient thermal deformation	
Work lamp	LED	compensation (FANUC)	

Optional Specifications · Options

Specifications	Remarks	Specifications	Remarks
Spindle speed 6,000 min ⁻¹	No. 50 2-speed gear head spindle 18.5/15 kW	Chip bucket Raised machine	Tilt with/without 100 mm
Spindle speed 12,000 min ⁻¹	No. 50 integral motor/spindle 26/18.5 kW (OSP) 22/18.5 kW (FANUC)	Workpiece washing gun Air gun mount Angle head preps	
Spindle speed 15,000 min ⁻¹	No. 40 integral motor/spindle 26/18.5 kW (OSP) 22/18.5 kW (FANUC)	Manual clamp fixture Hydraulic and pneumatic fixtures Oil skimmer	Belt type
ATC magazine	54 tools	Mist collector	
Chip air blower	Nozzle type	Rotary table	NC, tilt, indexing
Coolant pump	Pump motor: 550 W	Sub table	1,800 × 720 × 100 mm
Coolant nozzle	Ring type	Reference tool	
Semi-dry unit	Nozzle type, Thru-spindle type	Ring gauge	
Coolant level sensor		High column	+200 mm
Coolant temperature regulator		Auto gauging, auto zero offset	Infrared communication type
Oil hole device	0.5 MPa, 1.5 MPa	Auto tool length compensation/auto tool breakage detection function	Touch type
Thru-spindle coolant	Okuma pull stud for 1.5 MPa, 1.5 MPa large capacity, and 7 MPa required.	AbsoScale detection (OSP)	X-Y-Z axis
Spindle nose constraint	BIG-PLUS® No. 50 12,000 min ⁻¹ No. 40 15,000 min ⁻¹	Scale feedback (FANUC) Status lamp Foundation bolt	X-Y-Z axis
In-machine chip discharge	Oil pan: Chip flush	Parallel 2-pallet APC	Forms set together with below options. High column 200 mm Pallet size 1,700 × 700 mm Tap pallet, T-slot pallet
Off-machine chip discharge	Hinge conveyor, scraper conveyor		
	See recommended chip conveyor specifications, P31.		

Maximum tool dimensions

Unit: mm (in.)

No.50

■ Max tool size (adjacent tools)

■ Maximum tools used (w/o adjacent tools)

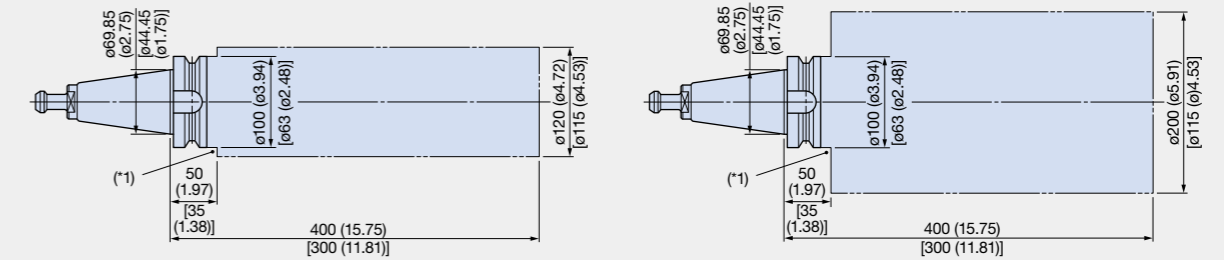

[]: No. 40 (15,000 min⁻¹ specs).

(*1): Interference with outer part of ATC tool change arm and tooling may occur with commercially available milling chucks, etc. Always be sure to check dimensions in tooling catalogues or other literature.

Table size

Unit: mm (in.)

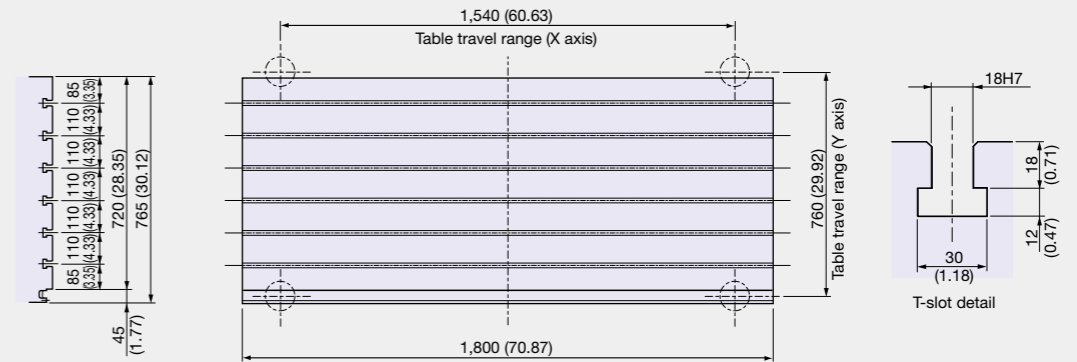

Working range

Unit: mm (in.)

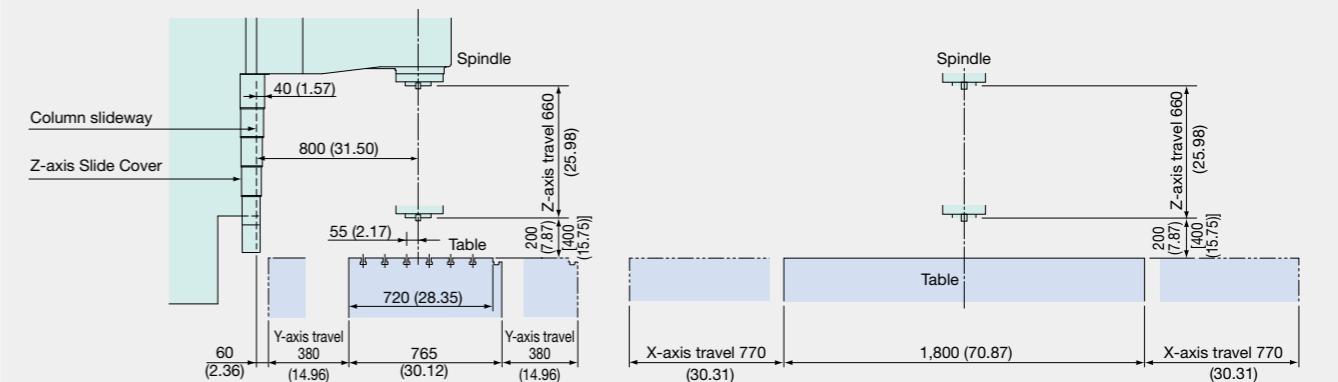

[]: High column specs

Vertical Machining Centers

MILLAC 852V II



Machine Specifications

Photos shown in this brochure may also show optional equipment.

Item	Unit	MILLAC 852V II			
		No. 50 4,000 min ⁻¹	No. 50 6,000 min ⁻¹	No. 50 12,000 min ⁻¹	No. 40 15,000 min ⁻¹
Travels	X axis (table R/L)	2,050 <3,050> (80.71 <120.08>)			
	Y axis (table F/B)	850 (33.46)			
	Z axis (spindle U/D)	750 (29.53)			
	Table top to spindle nose	200 to 950 <160 to 910> (7.87 to 37.40 <6.30 to 35.83>)			
	Column to spindle center	900 (35.43)			
Table	Work surface	2,200 <3,200> × 850 (86.61 <125.98> × 33.46)			
	Floor to table top	1,060 <1,100> (41.73 <43.31>)			
	Max load capacity	2,500 <3,800> (5,500 <8,360>)			
Spindle	Spindle speed	20 to 4,000	30 to 6,000	50 to 12,000	50 to 15,000
	Speed ranges	2-speed		Stepless (integral motor/spindle)	
	Tapered bore	7/24 taper No. 50			7/24 taper No. 40
	Bearing dia	ø100 (3.94)		ø90 (3.54)	
				ø70 (2.76)	
Feedrate	Rapid traverse	X-Y-Z: 16 <X-Y: 12, Z: 16> (X-Y-Z: 52 <X-Y: 39, Z: 52>)			
	Cutting feedrate	X-Y-Z: 10,000 (394)			
Motors	Spindle	kW (hp)		OSP:26/18.5 (35/25) (10 min/cont)	
				FANUC:22/18.5 (30/25) (15 min/cont)	
ATC	Tool storage	tool 36 [54]			
	Max tool dia (w, w/o adj tool)	ø120/ø200 (ø4.72/ø7.87)			ø115/ø115 (ø4.53/ø4.53)
	Max tool length	400 (15.75)			300 (11.81)
	Max tool weight	20 (44)			8 (11)
Machine size	Height	3,350 (131.89)		3,320 (130.71)	
	Floor space	5,460 × 4,445 <7,460 × 4,445> (214.96 × 175 <293.70 × 175>)			
	Weight	20,500 <22,500> (45,100 <49,500>)			
Control	OSP-P300MA, FANUC 31i-B				

< >: X-axis travel 3,050 specs []: Optional

Spindle torque/output graphs

No. 50 4,000 min⁻¹ spindle (OSP, FANUC)
Maximum output: 18.5/15 kW (30 min/cont)
Maximum torque: 587/476 N-m (30 min/cont)

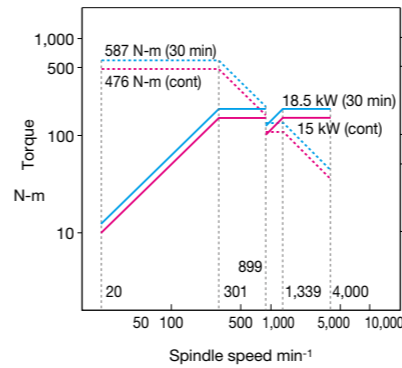

No. 50 6,000 min⁻¹ spindle (OSP, FANUC)
Maximum output: 18.5/15 kW (30 min/cont)
Maximum torque: 481/390 N-m (30 min/cont)

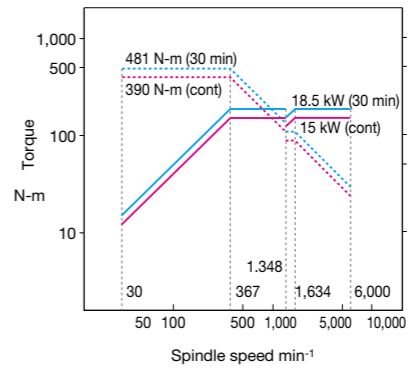

No. 50 12,000 min⁻¹ spindle (OSP)
Maximum output: 26/18.5 kW (10 min/cont)
Maximum torque: 199/146 N-m (5 min/cont)

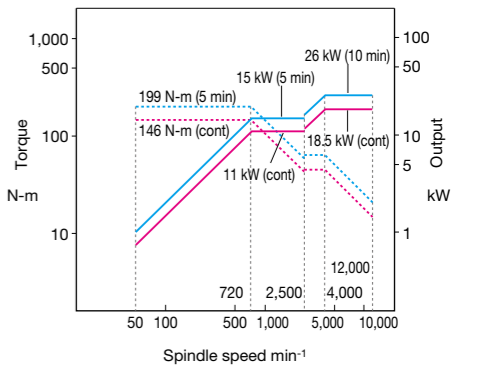

Dimensional drawing/Installation drawing

Unit: mm (in.)

No. 50 4,000/6,000 min⁻¹,
X-axis travel 2,050 specs

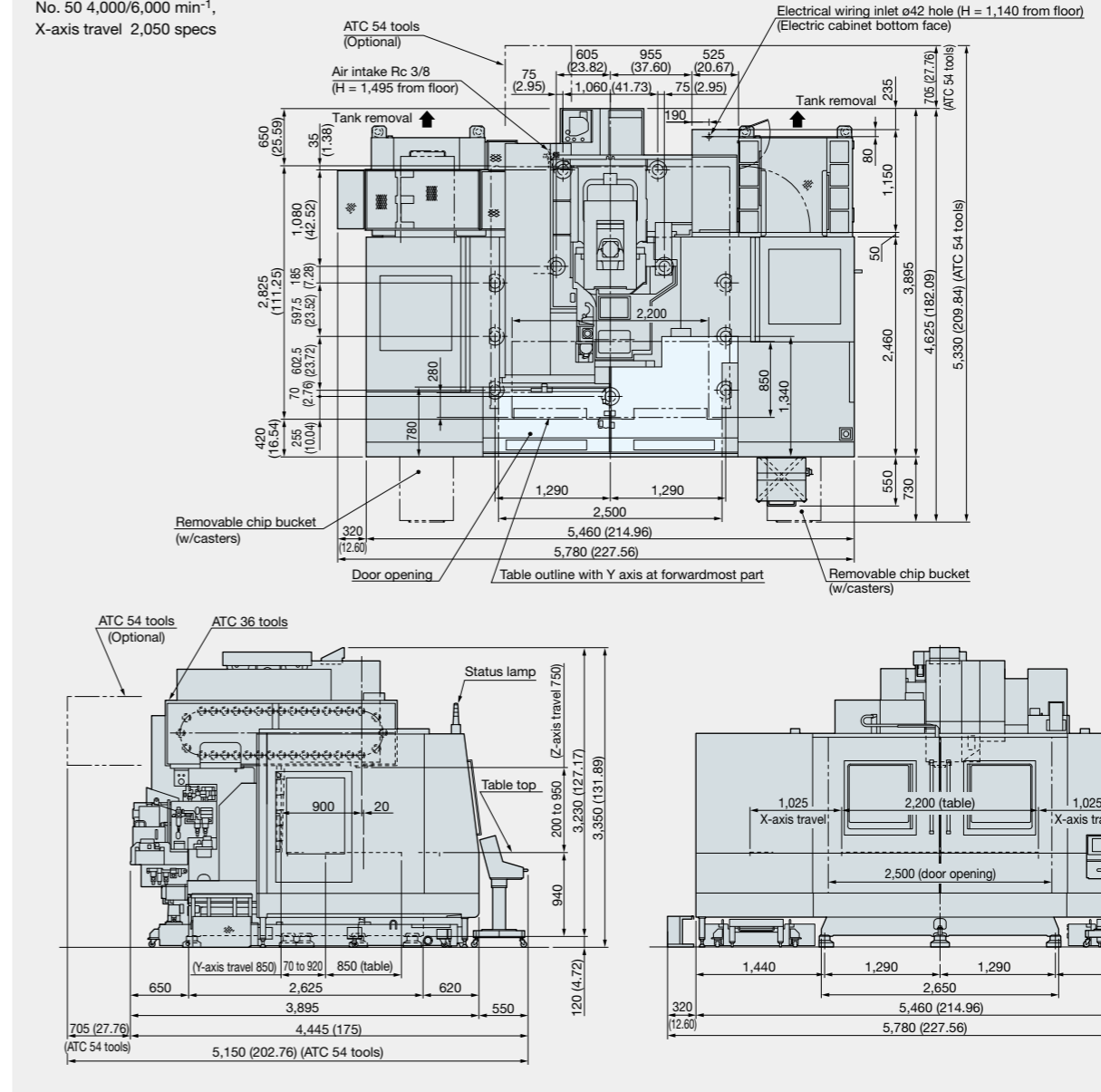

Machining Capacity (Material: S45C)

	Tool	Cutting Capacity (cm ³ /min) (in ³ /min)	Cutting Speed (m/min) (fpm)	Cutting Depth (mm) (in.)	Cutting Width (mm) (in.)	Feedrate (mm/min) (ipm)
No. 50 spindle 4,000 min ⁻¹ 2-speed gear head	ø150 face mill 8 blades	540 (32.96)	165 (541.37)	5 (0.20)	90 (3.54)	1,200 (47.24)
		485 (29.61)	165 (541.37)	7 (0.28)	90 (3.54)	770 (30.31)
	ø40 roughing end mill	252 (15.38)	25 (82.03)	40 (1.57)	30 (1.18)	210 (8.27)
		252 (15.38)	25 (82.03)	30 (1.18)	40 (1.57)	210 (8.27)

Note: The "actual data" referred to above for this brochure represent examples, and may not be obtained due to differences in specifications, tooling, cutting, and other conditions.

Standard Specifications · Accessories

Specifications	Remarks	Specifications	Remarks
CNC	OSP-P300MA	Spindle air curtain	
	FANUC 31i-B	Air cleaner (filter)	Including regulator
Spindle speed	4,000 min ⁻¹ No. 50	Door interlock	
	2-speed gear head spindle	Pulse handle	Single axis, switchable
	Spindle motor 18.5/15 kW	Electronic buzzer	At operation end and alarm times
Spindle nose constraint	BIG-PLUS® (No. 50 4,000, 6,000 min ⁻¹ specs)	Foundation blocks / Jack bolts	
		Tool / Tool box	Hand tools
Spindle cooling system	Oil controller	Tool release lever	
ATC magazine	36 tools	Bed-mounted operation panel	
ATC air blower		TAS-S: Thermo Active dimension	
Full-enclosure	With ceiling	Stabilizer - Spindle (OSP)	
Slideway lubricating equipemnt		TAS-C: Thermo Active dimension	
In-machine conveyor	Table rear: Coil	Stabilizer - Construction (OSP)	
Chip pan		Spindle thermal deformation compensation (FANUC)	
Coolant supply system	Tank: 900 L, Pump motor: 250 W	Ambient thermal deformation compensation (FANUC)	
Coolant nozzle	3 flexible nozzles		
Work lamp	LED		

Optional Specifications · Options

Specifications	Remarks	Specifications	Remarks
Spindle speed 6,000 min ⁻¹	No. 50 2-speed gear head spindle 18.5/15 kW	Chip bucket	Tilt with/without
		Raised machine	100 mm
Spindle speed 12,000 min ⁻¹	No. 50 integral motor/spindle 26/18.5 kW (OSP) 22/18.5 kW (FANUC)	Workpiece washing gun	
		Air gun mount	
		Angle head preps	
Spindle speed 15,000 min ⁻¹	No. 40 integral motor/spindle 26/18.5 kW (OSP) 22/18.5 kW (FANUC)	Manual clamp fixture	
		Hydraulic and pneumatic fixtures	
		Oil skimmer	Belt type
ATC magazine	54 tools	Mist collector	
Chip air blower	Nozzle type	Rotary table	NC, tilt, indexing
Coolant pump	Pump motor : 550 W	Sub table	2,200 × 850 × 100 mm
Coolant nozzle	Ring type	Reference tool	
Semi-dry unit	Nozzle type, Thru-spindle type	Ring gauge	
Coolant level sensor		High column	+200 mm
Coolant temperature regulator		Auto gauging, auto zero offset	Infrared communication type
Oil hole device	0.5 MPa, 1.5 MPa	Auto tool length compensation/auto tool breakage detection function	Touch type
Thru-spindle coolant	Okuma pull stud for 1.5 MPa, 1.5 MPa large capacity, and 7 MPa required.	AbsoScale detection (OSP)	X-Y-Z axis
		Scale feedback (FANUC)	X-Y-Z axis
Spindle nose constraint	BIG-PLUS® No. 50 12,000 min ⁻¹ No. 40 15,000 min ⁻¹	Status lamp	
		Foundation bolt	
		Parallel 2-pallet APC (X-axis travel 2,050 mm specifications only)	High column 200 mm Pallet size 2,200 × 820 mm Tap pallet, T-slot pallet
In-machine chip discharge	Oil pan: Chip flush		
Off-machine chip discharge	Hinge conveyor, scraper conveyor		
	See recommended chip conveyor specifications, P31.		

Maximum tool dimensions

Unit: mm (in.)

No.50

■ Max tool size (adjacent tools)

■ Maximum tools used (w/o adjacent tools)

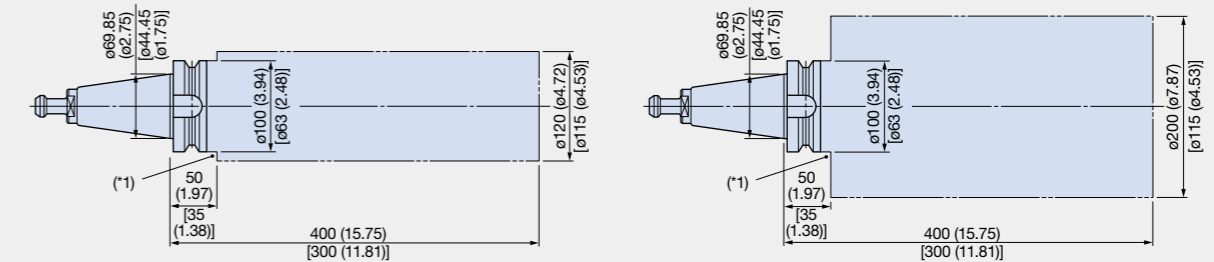

[] : No. 40 (15,000 min⁻¹ specs).

(*) : Interference with outer part of ATC tool change arm and tooling may occur with commercially available milling chucks, etc. Always be sure to check dimensions in tooling catalogues or other literature.

Table size

Unit: mm (in.)

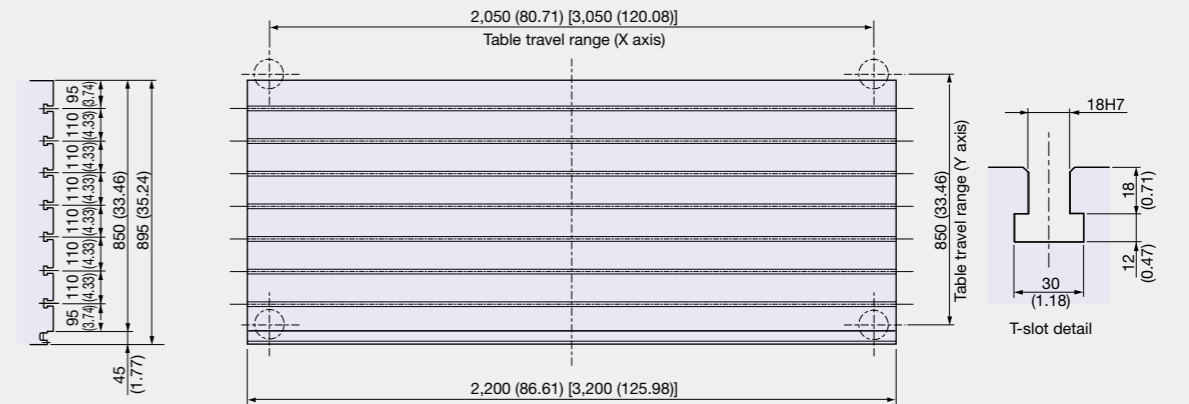

[] : X-axis travel 3,050 mm (120.08 in.) specs

Working range

Unit: mm (in.)

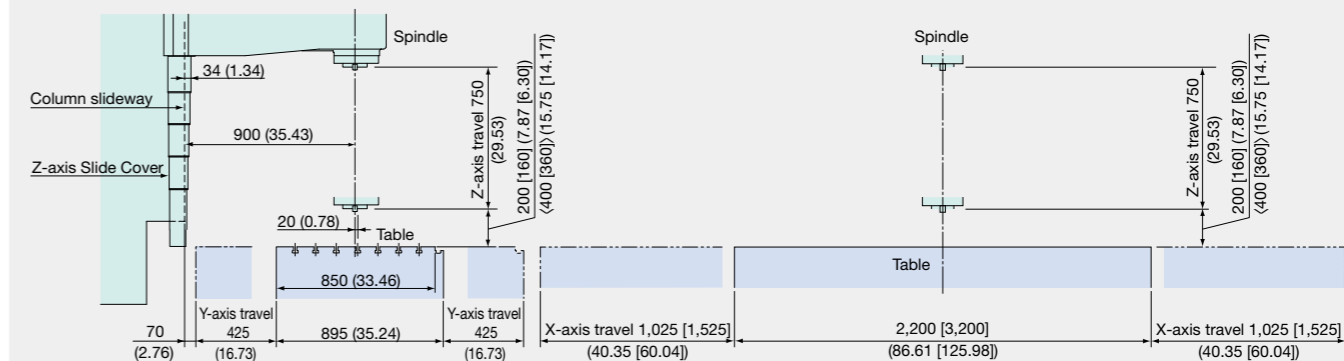

< > : High column specs [] : X-axis travel 3,050 mm (120.08 in.) specs

Vertical Machining Centers

MILLAC 1052V II

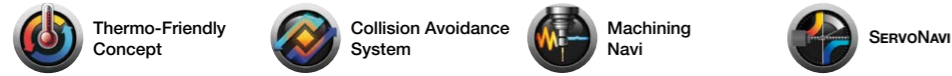

Machine Specifications

Photos shown in this brochure may also show optional equipment.

Item	Unit	MILLAC 1052V II			
		No. 50 4,000 min ⁻¹	No. 50 6,000 min ⁻¹	No. 50 12,000 min ⁻¹	No. 40 15,000 min ⁻¹
Travels	X axis (table R/L)	2,050 <3,050> (80.71 <120.08>)			
	Y axis (table F/B)	1,060 (41.73)			
	Z axis (spindle U/D)	800 (31.50)			
	Table top to spindle nose	200 to 1,000 <160 to 960> (7.87 to 39.37 <6.30 to 37.80>)			
	Column to spindle center	1,100 (43.31)			
Table	Work surface	2,200 <3,200> × 1,050 (86.61 <125.98> × 41.34)			
	Floor to table top	1,060 <1,150> (41.73 <45.28>)			
	Max load capacity	5,000 (11,000)			
Spindle	Spindle speed	20 to 4,000	30 to 6,000	50 to 12,000	50 to 15,000
	Speed ranges	2-speed		Stepless (integral motor/spindle)	
	Tapered bore	7/24 taper No. 50			7/24 taper No. 40
	Bearing dia	ø100 (3.94)		ø90 (3.54)	
				ø70 (2.76)	
Feedrate	Rapid traverse	X-Y-Z: 16 <X-Y: 12, Z: 16> (X-Y-Z: 52 <X-Y: 39, Z: 52>)			
	Cutting feedrate	X-Y-Z: 10,000 (394)			
Motors	Spindle	22/18.5 (30/25) (30 min/cont)		OSP:26/18.5 (35/25) (10 min/cont) FANUC:22/18.5 (30/25) (15 min/cont)	
ATC	Tool storage	36 [54]			
	Max tool dia (w, w/o adj tool)	ø120/ø200 (ø4.72/ø7.87)			ø115/ø115 (ø4.53/ø4.53)
	Max tool length	400 (15.75)			300 (11.81)
	Max tool weight	20 (44)			8 (11)
Machine size	Height	3,520 <3,570> (138.58 <140.55>)			
	Floor space	6,760 × 4,470 <9,065 × 4,495> (266.14 × 175.98 <356.89 × 176.67>)			
	Weight	25,200 <29,600> (55,440 <65,120>)			
Control		OSP-P300MA, FANUC 31i-B			

< >: X-axis travel 3,050 specs []: Optional

Spindle torque/output graphs

No. 50 4,000 min⁻¹ spindle (OSP, FANUC)
Maximum output: 22/18.5 kW (30 min/cont)
Maximum torque: 827/695 N-m (30 min/cont)

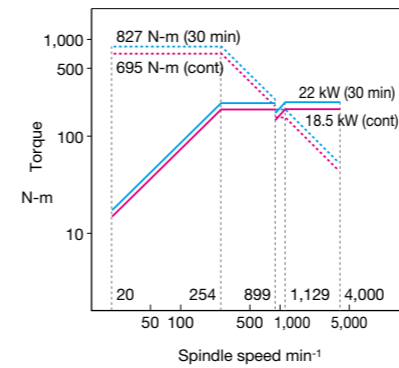

No. 50 6,000 min⁻¹ spindle (OSP, FANUC)
Maximum output: 22/18.5 kW (30 min/cont)
Maximum torque: 511/430 N-m (30 min/cont)

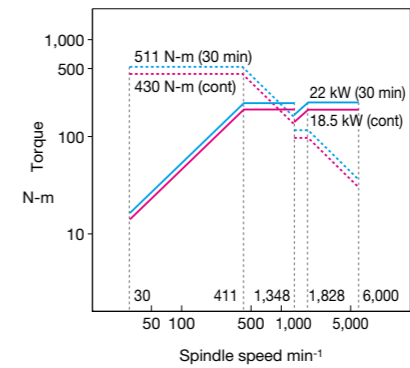

No. 50 12,000 min⁻¹ spindle (OSP)
Maximum output: 26/18.5 kW (10 min/cont)
Maximum torque: 199/146 N-m (5 min/cont)

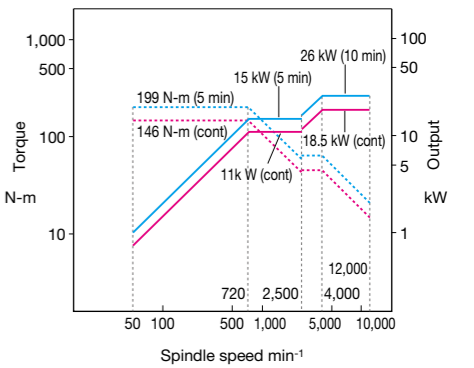

Dimensional drawing/Installation drawing

Unit: mm (in.)

No. 50 4,000/6,000 min⁻¹,
X-axis travel 2,050 specs

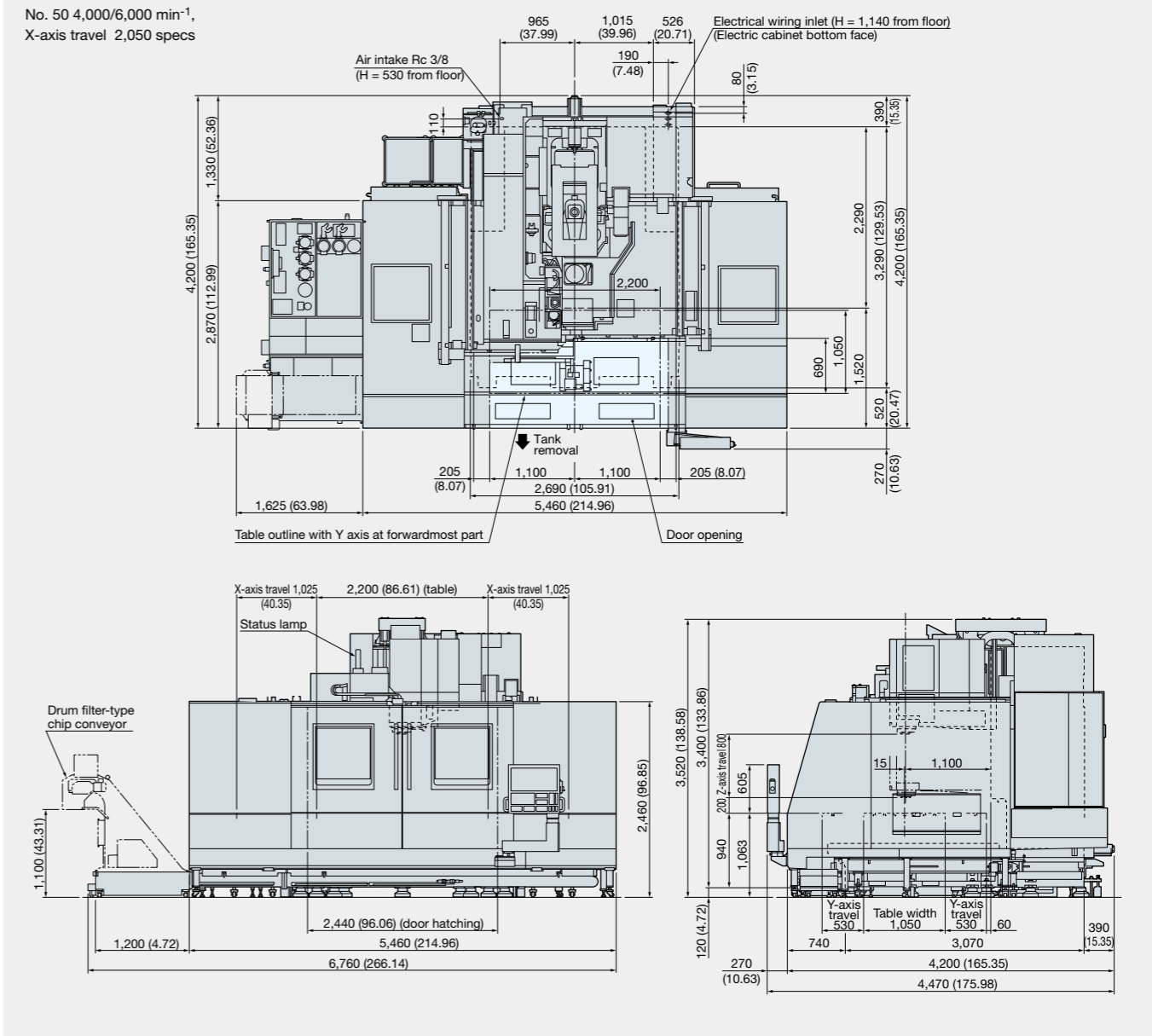

Machining Capacity (Material: S45C)

	Tool	Cutting Capacity (cm ³ /min) (in ³ /min)	Cutting Speed (m/min) (fpm)	Cutting Depth (mm) (in.)	Cutting Width (mm) (in.)	Feedrate (mm/min) (ipm)
No. 50 spindle 4,000 min ⁻¹ 2-speed gear head	ø150 face mill 8 blades	720 (43.96)	165 (541.37)	5 (0.20)	90 (3.54)	1,600 (62.99)
		756 (46.15)	165 (541.37)	7 (0.28)	90 (3.54)	1,200 (47.24)
	ø40 roughing end mill	360 (21.98)	25 (82.03)	30 (1.18)	40 (1.57)	300 (11.81)

Note: The "actual data" referred to above for this brochure represent examples, and may not be obtained due to differences in specifications, tooling, cutting, and other conditions.

Standard Specifications · Accessories

Specifications	Remarks	Specifications	Remarks
CNC	OSP-P300MA	Work lamp	LED
	FANUC 31i-B	Spindle air curtain	
Spindle speed	4,000 min ⁻¹ No. 50	Air cleaner (filter)	Including regulator
	2-speed gear head spindle	Door interlock	
	Spindle motor 22/18.5 kW	Pulse handle	Single axis, switchable
Spindle nose constraint	BIG-PLUS® (No. 50 4,000, 6,000 min ⁻¹ specs)	Electronic buzzer	At operation end and alarm times
		Foundation blocks / Jack bolts	
Spindle cooling system	Oil controller	Tool / Tool box	Hand tools
ATC magazine	36 tools	Tool release lever	
ATC air blower		TAS-S: Thermo Active dimension	
Full-enclosure	With ceiling	Stabilizer - Spindle (OSP)	
Slideway lubricating equipemnt		TAS-C: Thermo Active dimension	
In-machine conveyor	Table rear: Coil	Stabilizer - Construction (OSP)	
	Left: floor, right: pan	Spindle thermal deformation compensation (FANUC)	
Chip pan		Ambient thermal deformation compensation (FANUC)	
Coolant supply system	Tank: 750 L, Pump motor: 250 W		
Coolant nozzle	3 flexible nozzles		

Optional Specifications · Options

Specifications	Remarks	Specifications	Remarks
Spindle speed 6,000 min ⁻¹	No. 50 2-speed gear head spindle 22/18.5 kW	Chip bucket	Tilt with/without (L-type, H-type)
		Raised machine	
Spindle speed 12,000 min ⁻¹	No. 50 integral motor/spindle 26/18.5 kW (OSP) 22/18.5 kW (FANUC)	Workpiece washing gun	
		Air gun mount	
		Angle head preps	
Spindle speed 15,000 min ⁻¹	No. 40 integral motor/spindle 26/18.5 kW (OSP) 22/18.5 kW (FANUC)	Manual clamp fixture	
		Hydraulic and pneumatic fixtures	
		Oil skimmer	Belt type
ATC magazine	54 tools	Mist collector	
Chip air blower	Nozzle type	Rotary table	NC, tilt, indexing
Coolant pump	Pump motor : 550 W	Sub table	2,200 × 1,050 × 100 mm
Coolant nozzle	Ring type	Reference tool	
Semi-dry unit	Nozzle type, Thru-spindle type	Ring gauge	
Coolant level sensor		High column	+150 mm
Coolant temperature regulator		Auto gauging, auto zero offset	Infrared communication type
Oil hole device	0.5 MPa, 1.5 MPa	Auto tool lengh compensation/auto tool breakage detection function	Touch type
Thru-spindle coolant	Okuma pull stud for 1.5 MPa, 1.5 MPa large capacity, and 7 MPa required.	Pulse handle	3-axis mobile type
Spindle nose constraint	BIG-PLUS® No. 50 12,000 min ⁻¹ No. 40 15,000 min ⁻¹	AbsoScale detection (OSP)	X-Y-Z axis, X-Y axis
		Scale feedback (FANUC)	X-Y-Z axis, X-Y axis
		Status lamp	
In-machine chip discharge	Oil pan: Chip flush	Foundation bolt	
	Left: floor, right: floor	Parallel 2-pallet APC (X-axis travel 2,050 mm specifications only)	Forms set together with below options. High column 150 mm Pallet size 2,200 × 1,020 mm Tap pallet, T-slot pallet
Off-machine chip discharge	Hinge conveyor, scraper conveyor		
	Scraper type (with drum filter) conveyor See recommended chip conveyor specifications, P31.		

Maximum tool dimensions

Unit: mm (in.)

No.50

■ Max tool size (adjacent tools)

■ Max tool size (adjacent tools)

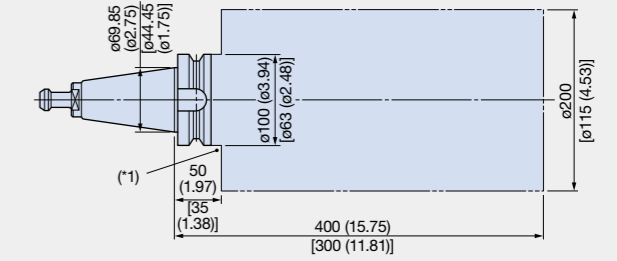
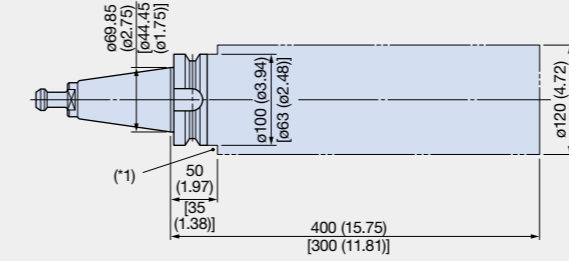

[]: No. 40 (15,000 min⁻¹ specs).

(*1): Interference with outer part of ATC tool change arm and tooling may occur with commercially available milling chucks, etc. Always be sure to check dimensions in tooling catalogues or other literature.

Table size

Unit: mm (in.)

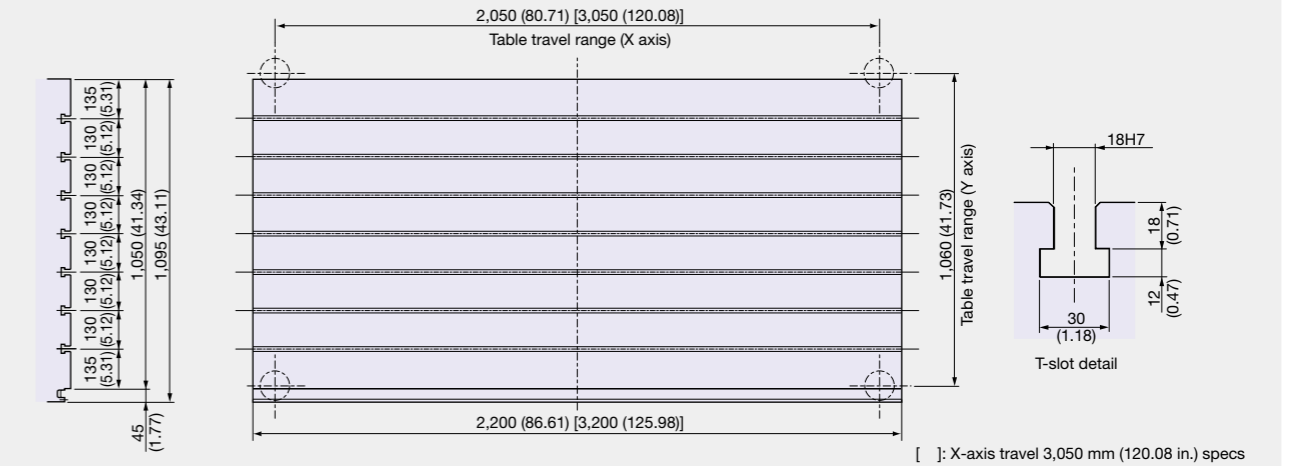

[]: X-axis travel 3,050 mm (120.08 in.) specs

Working range

Unit: mm (in.)

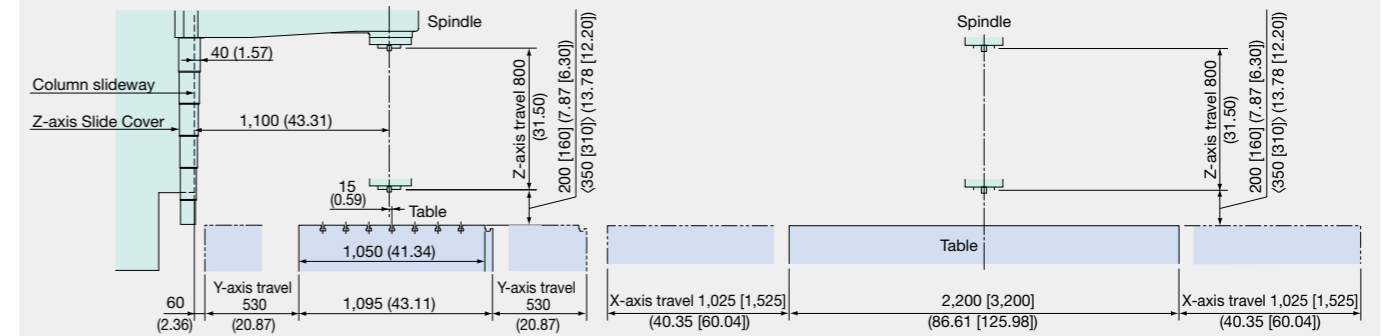

< >: High column specs []: X-axis travel 3,050 mm (120.08 in.) specs

Smooth discharge of even large volumes of chips

Recommended Chip Conveyors (Please contact an Okuma sales representative for details.)

Workpiece material		Steel	FC	Aluminum / Nonferrous	Mixed (general use)
Chip shape					
In-machine	Coil	○	○	○	○
Off-machine*	Hinge	○	—	—	△(*4)
	Scraper	—	○ (Dry)	—	—
	Scraper (with drum filter)	—	○ (Wet) with magnet	△(*3)	—
	Hinge + scraper (with drum filter)	△(*1)	△ (Wet) (*2)	○	○

*1. When there are many fine chips *2. When chips are longer than 100 mm *3. When chips are shorter than 100 mm *4. When there are few fine chips

Note: Fire prevention measures are necessary, as use of oil-based coolant may cause fire.

*With the MILLAC 1052VII, a hinge conveyor with drum filter is attached when discharging chips off-machine.

Off-machine lift-up chip conveyors

Type	Hinge	Scraper	Scraper (with drum filter)	Hinge + scraper (with drum filter)
Shape				

Note: Even if the conveyor has a drum filter, its coolant tank must be cleaned periodically.



In-machine chip discharge: Coil
MILLAC 468VII

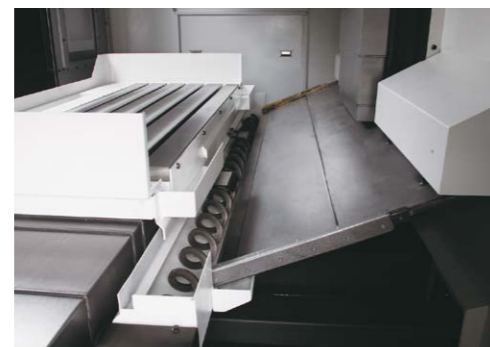

In-machine chip discharge: Coil
MILLAC 611VII



Off-machine chip discharge:
Lift-up conveyor (Optional)
MILLAC 761VII

The Next-Generation Intelligent CNC

OSP suite *OSP-P300MA*

With revamped operation and responsiveness—ease of use for machine shops first!

Smart factories implement advanced digitization and networking (IoT) in "Monozukuri," (manufacturing) achieving enhanced productivity and added value.

The OSP has evolved tremendously as CNC control suited to advanced intelligent technology. Okuma's new control uses the latest CPUs for a tremendous boost in operability, rendering performance, and processing speed.

The OSP suite also features a full range of useful apps that could only come from a machine-tool manufacturer, making smart manufacturing a reality.

Smooth, comfortable operation with the feeling of using a smart phone

Improved rendering performance and use of a multi-touch panel achieve intuitive graphical operation. Moving, enlarging, reducing, and rotating 3D models, as well as list views of tool data, programs, and other information can be accomplished through smooth, speedy operations with the same feel as using a smart phone.

The screen display layout on the operation screen can also be changed to suit operator tastes, and customized for needs from beginning to veteran operator.



Note: Collision Avoidance System (Optional) shown above.

Features you wanted – loaded with OSP suite apps!

We made these real through the addition of Okuma's machining expertise based on requests we heard from customers in the machine shop. These are filled with intelligence that enhances the "strength in the field" that CNC control can accomplish because it's created by a machine-tool manufacturer.



Routine inspection support
Maintenance monitor

The Maintenance Monitor displays items for inspections before starting daily operation and regular inspections and the rough estimate of inspection timing. Touching the [INFO] button displays the PDF instruction manual file of relevant maintenance items.

PERIODICAL MAINTENANCE		DAILY INSPECTION		CHANGE MODE		
NO	ITEM	WORK	PROGRESS	REMAIN	INFO	EXECUTE
310	Ceases for tool clamping unit (PDR)	Supply		5h		
311	Packing in tool clamping unit (PDR)	Inspection		5h		
320	Z-axis contour lubrication oil	Replace		1000h		
411	Hydraulic unit oil	Replace		0h		
412	Hydraulic unit line filter	Cleaning		1h		
413	Hydraulic unit line filter	Replace		5h		
421	Oil for SPCL cooling unit	Replace		1000h		

[INFO] button



Increased productivity through visualization of motor power reserve
Spindle Output Monitor



Monitoring utilization status even when away from the machine
E-mail Notification



Comment display for greater ease of use and faster work
Common Variable Monitor



Automatic saving of recorded alarms
Screen Capture



Easy programing without keying in code
Scheduled Program Editor

Fire Safety Precautions

To protect your factory and equipment from fire and assure continued safe operation, observe the following fire safety precautions whenever you operate machinery.

Whenever possible, avoid the use of oil-based coolants for cutting operations.

Sparks caused by hot chips, tool friction, and grinding can cause fires.

Always observe the following safety measures to ensure safe operation when machining flammable materials or when performing dry machining.

1. Oil-based coolant
 - (1) Use nonflammable cutting fluid coolant.
 - (2) When the use of an oil-based coolant is unavoidable:
 - **Before** you begin machining, check cutting tools to make sure of their service life and the condition of the tool edge, and choose cutting conditions that will not cause a fire.
 - Periodically clean the coolant filter to maintain sufficient coolant discharge, and frequently verify that coolant is discharging normally.
 - Take measures to control the outbreak of fire: Place a fire extinguisher near the machine, have an operator constantly monitor operation, and install an automatic fire extinguishing system.
 - Do not place flammable materials near the machine.
 - Do not allow chips to over accumulate.
 - Periodically clean the inside of the machine and the area surrounding it.
 - Check that the machine is operating normally.
 - Never run the machine unattended.
 - Since an automatic fire extinguishing system and other peripherals are needed for grinding operations, please let us know as soon as possible if you plan to perform such operations.
2. Precautions regarding machining of potentially flammable materials

Before machining any material designated by law as a flammable substance, e.g., plastic, rubber, wood, acquaint yourself with the special characteristics of the material in terms of fire prevention, and observe the precautions given in (2) above to ensure safe operation.

Example: When machining magnesium, there is a danger that magnesium chips and water-soluble coolants will react to produce hydrogen gas, resulting in an explosive fire if any chip should ignite.
3. Dry machining

Dry machining is a fire hazard because workpieces, tools, and chips are not cooled. To ensure safe operation, do not place any flammable objects near the machine and do not allow chips to over accumulate.

In addition, be sure to check cutting tools to make sure of their service life and the condition of the tool edge, and observe the precautions regarding oil-based coolants given in (2) above.



OKUMA Corporation

Oguchi-cho, Niwa-gun,
Aichi 480-0193, Japan
TEL: +81-587-95-7825 FAX: +81-587-95-6074